



Made for ideas.

LACIE 8BIG RACK THUNDERBOLT 2 USER MANUAL



CLICK [HERE](#) TO ACCESS AN **UP-TO-DATE ONLINE VERSION**

of this document. You will find the most recent content as well as expandable illustrations, easier navigation, and search capability.



INTRODUCTION

WHAT IS IN THIS MANUAL

Welcome to the User Manual for the LaCie 8big Rack Thunderbolt™ 2. The LaCie 8big is a rackmount direct-attached storage, or DAS. Connect it to a computer that supports Thunderbolt 2 technology for transfer rates that reach up to 20Gb/s. LaCie has constructed the LaCie 8big to

handle bandwidth-intensive content such as 4K video and 3D graphics. This means that professional editors, photographers, and graphic artists get the highest performing storage for their most challenging projects.

Use this manual to guide you through the process of connecting your LaCie storage. For questions on installation, consult the [Getting Help](#) page.



BOX CONTENTS

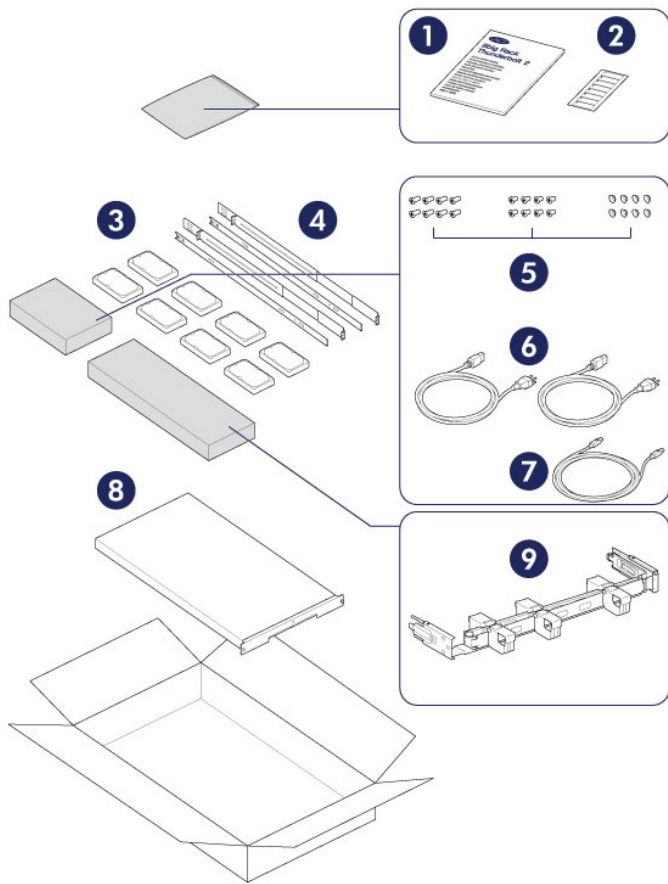

1. Quick Install Guide
2. Drive stickers
3. Hard drives (the amount of hard drives can vary by model)
4. Inner rack rails (A1, A2) and outer rack rails (B1, B2)
5. Inner rack rail screws (M4x4); outer rack rail screws (M5x10) and washers (W)
6. Power supply cables (certain models are shipped with one power supply cable)
7. Thunderbolt cable (2m)
8. LaCie 8big Rack Thunderbolt 2
9. Cable management arm kit

An additional plastic bag with screws has been provided to fasten hard drives to the drive drawers. If you must secure hard drives to the hard drive trays, make certain to use the included screws.

Important info: Save your packaging. In the event that the product should need to be repaired or serviced, it must be returned in its original packaging.

Software suite

Visit [LaCie 8big Rack Thunderbolt 2 software](#) to download your free suite of utilities including:

- LaCie RAID Manager (manage the LaCie 8big storage)
- Intego® Backup Manager Pro (configure automated backups)
- LaCie Private-Public (protect data with AES 256-bit encryption)

MINIMUM SYSTEM REQUIREMENTS

Client types

- Mac OS X 10.9 and later
- Windows 7 and later
- A computer that supports Thunderbolt 2 technology or first generation Thunderbolt technology. To take advantage of the higher performance offered by Thunderbolt 2 technology, your computer must have a Thunderbolt 2 technology port (see [LaCie 8big Rack Thunderbolt 2: Advanced Storage Technology](#)).

Important info:

Your LaCie product's performance can be affected by such external forces as type of cable, hardware, distance, and setup.

For optimal performance: use the cables provided with your device or, cables supported by LaCie; make certain to follow the installation instructions provided in the Quick Install Guide and this user manual.

LACIE 8BIG RACK THUNDERBOLT 2: ADVANCED STORAGE TECHNOLOGY

THUNDERBOLT 2 TECHNOLOGY

The LaCie 8big Rack Thunderbolt 2 uses Thunderbolt 2 technology, the fastest, most versatile connection for your computer. While first generation Thunderbolt technology transfer rates are 10Gb/s bi-directional, Thunderbolt 2 technology provides 20Gb/s bi-directional. Additionally, Thunderbolt 2 technology gives priority to the video stream, apportioning the required bandwidth for playback. This is a critical advantage when working with high-end video and 3D graphics.

For example, a film editor is working with two streams, 4K video at 12Gb/s and data at 4Gb/s. Whereas first generation Thunderbolt technology may experience difficulty with the video signal, Thunderbolt 2 technology allows it to pass without a problem, dividing the bandwidth as needed for playback.

Important cable info: When connecting your Thunderbolt enclosure to a computer or compatible devices, use cables specifically constructed to support Thunderbolt technology.

Important info: A Thunderbolt enclosure must be connected to a computer that supports Thunderbolt technology. While the ports on the back of the device can easily seat Mini DisplayPort cable ends for daisy chaining displays, the Thunderbolt storage will only work when connected to a computer that supports Thunderbolt technology.

LACIE 8BIG RACK THUNDERBOLT 2 TECHNOLOGY: HIGH-END HARDWARE FOR PERFORMANCE AND REDUNDANCY

Featuring hardware RAID and redundant components, the LaCie 8big is a rarity in the world of high-end DAS. While most DAS must choose between high transfer rates or data protection, the LaCie 8big offers both extraordinary performance and built-in protection. Its powerful RAID engine saves your computer from expending critical processing resources on storage management, which is crucial for video and graphics applications that place heavy demands on computer CPUs. Further, hardware RAID solutions offer advanced RAID configurations to suit the needs of your working environment (see [RAID](#)).

The LaCie 8big Rack Thunderbolt 2 features:

- 1U Rackmount form factor
- Aluminum front and all-metal enclosure
- A RAID-on-Chip (RoC) processor to manage the RAID
- Hardware RAIDs 0, 1, 10, 5, 6, and JBOD
- Eight SATA channels, up to 6Gb/s per channel
- Two Thunderbolt 2 technology ports, up to 20Gb/s bi-directional per port
- Hot-swappable hard drives, fans, and power supplies to reduce downtime
- Redundant power supply bays
- A warning system with physical and email alerts
- Intelligent RAID rebuild with a spare hard drive

SYSTEM OVERVIEW

The LaCie 8big Rack Thunderbolt 2 is a 1U-sized hard drive enclosure. It houses up to eight 3.5-inch hard drives in its front chassis.

Enclosures shipped with hard drives feature high-performance Seagate Desktop HDD.

In case of hard drive failure or, the need to expand storage capacity, each individual hard drive is hot-swappable and field replaceable. New or replacement hard drives must meet the following requirements:

- SATA I or higher
- 3.0Gb/s or higher
- Spin up to 7200 RPM

For further information on compatible hard drives, visit [LaCie technical support](#).

SPECIFICATIONS

Storage management

The LaCie 8big storage is managed by the software utility LaCie RAID Manager. See [Software](#).

Enclosure dimensions

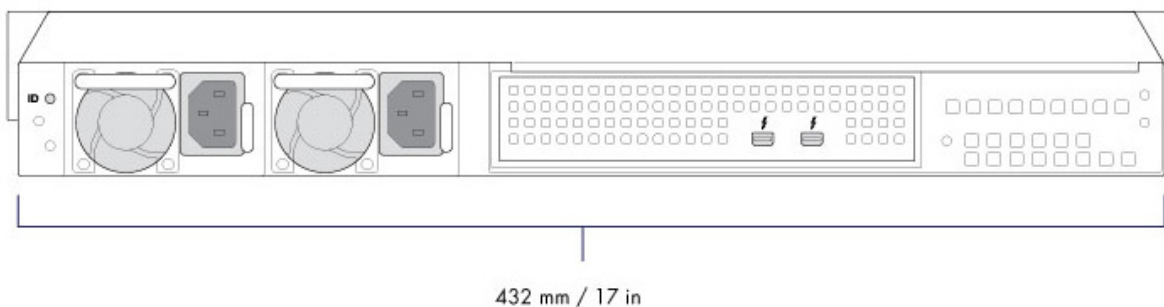
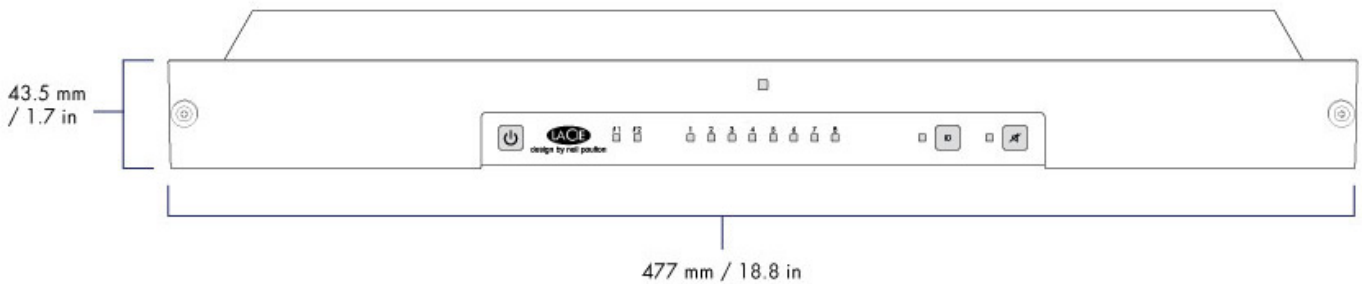

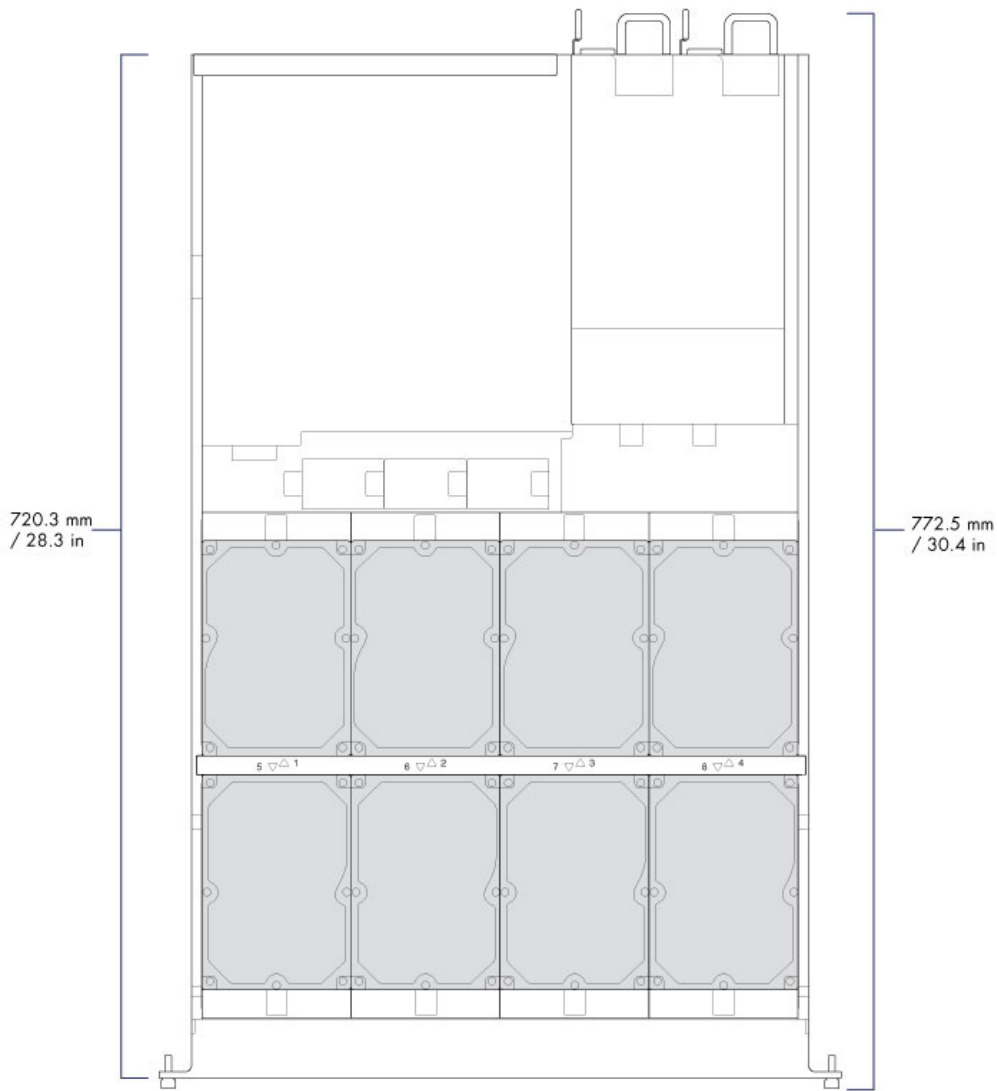

Enclosure weight

Hard drives	Weight
0	15 Kg / 33 lbs
4	18 Kg / 40 lbs
8	20 Kg / 44 lbs

Temperature ranges

Ambient environment	Temperature range
Standard (operating)	+5°C to +40°C
Storage (non-operating)	-20°C to +60°C

Important info: The maximum operating ambient temperature for the LaCie 8big is 40°C. Should the environment remain above 40°C for an extended period of time, there is a strong risk that the enclosure will automatically spin down the hard drives and enter idle mode (see [Operation](#)). This is a safety precaution to protect the hard drives.

Humidity

Environment	Humidity range
Standard (operating)	10% to 60% non-condensing
Storage (non-operating)	5% to 85% non-condensing

Electrical

Power supply: 100-240V; 50/60Hz; 250W

Acoustics

State	Noise (dBA)
Idle	50 @ 1 m
Operational	53 @ 1 m
Operational max	69 @ 1 m

Note: These measurements have been made under normal conditions, one meter/three feet from the front of the product. It may vary with conditions and product configuration.

VIEWS

Front panel view

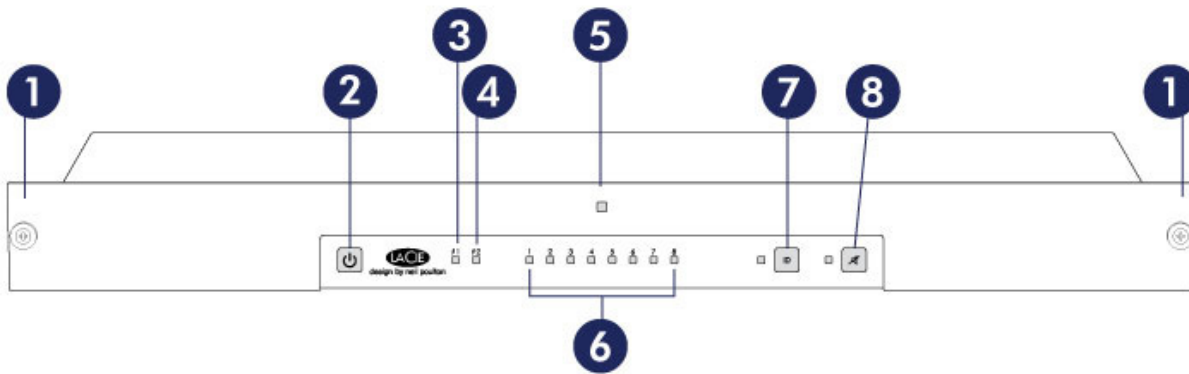

1. **Rackmount brackets:** Attaches the LaCie 8big Rack Thunderbolt 2 to standard, 19-inch computer equipment racks. See [Setting Up](#).
2. **Power button:** Push to turn the system on or to enter idle mode. See [Operation](#).
3. **Thunderbolt host LED:** The LED will turn blue when it is connected to a computer that is compatible with Thunderbolt 2 technology or first generation Thunderbolt technology. See [System LEDs](#).
4. **Thunderbolt daisy chain LED:** The LED will turn blue when the LaCie 8big is connected to compatible Thunderbolt devices and displays. See [Daisy Chain](#) and [System LEDs](#).
5. **Status LED:** Indicates that the device is powered on and provides status signals. See [System LEDs](#).
6. **Hard drive LEDs:** Indicates the status and activity for the hard drives in the enclosure. See [System LEDs](#).
7. **Identification button:** Pushing this button will cause the identification LEDs on the front and rear of the LaCie 8big to blink amber. The alarm will also sound. The flashing LEDs allow you to identify the LaCie 8big among a group of racked devices. There is another identification button on the rear of the device that can also be pushed to turn on the identification LEDs and sound the alarm. Both buttons work in tandem, allowing you to turn the visual and audio identifications on and off. For example, you can use the identification button on the front of the device to turn them on and then turn them off via the rear identification button.
8. **Mute button:** Push the button to turn off the sound for an audio alarm. An audible alarm will sound when someone pushes an identification button or, if the unit senses a problem with the hardware, such as a faulty power supply unit or elevated temperatures. When the Mute button is pushed, its LED will turn amber, indicating that the alarm is on but the sound has been turned off.

For details on LED behavior. See [System LEDs](#).

Rear panel view

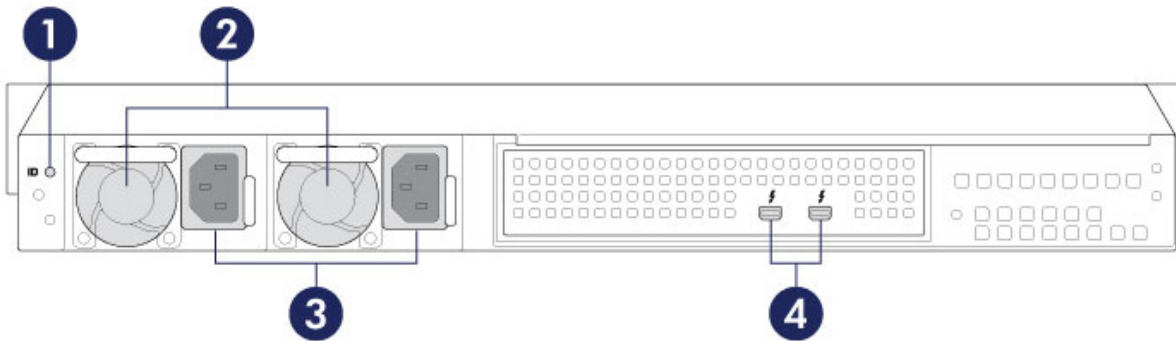

1. **Identification button and LED:** Pushing this button will cause the identification LEDs on the front and rear of the LaCie 8big to blink amber. The alarm will also sound. The flashing LEDs allow you to identify the LaCie 8big among a group of racked devices. There is another identification button on the front of the device that can also be pushed to turn on the identification LEDs and sound the alarm. Both buttons work in tandem, allowing you to turn the visual and audio identifications on and off. For example, you can use the identification button on the front of the device to turn them on and then turn them off via the rear identification button.
2. **Ventilation:** Helps to keep the LaCie 8big's power supply units cool during operation. Do not block the ventilation when using the product.
3. **Power inputs:** Insert the AC adapter supplied with the hard drive. See [Setting Up](#).
4. **Thunderbolt ports:** The ports are flexible when connecting the LaCie 8big to your computer and Thunderbolt peripherals. You can use either port as the host, connected to a computer or, the daisy chain, connected to compatible Thunderbolt 2 and first generation Thunderbolt devices. See [Setting Up](#) and [Daisy Chain](#).

Hard drive frames

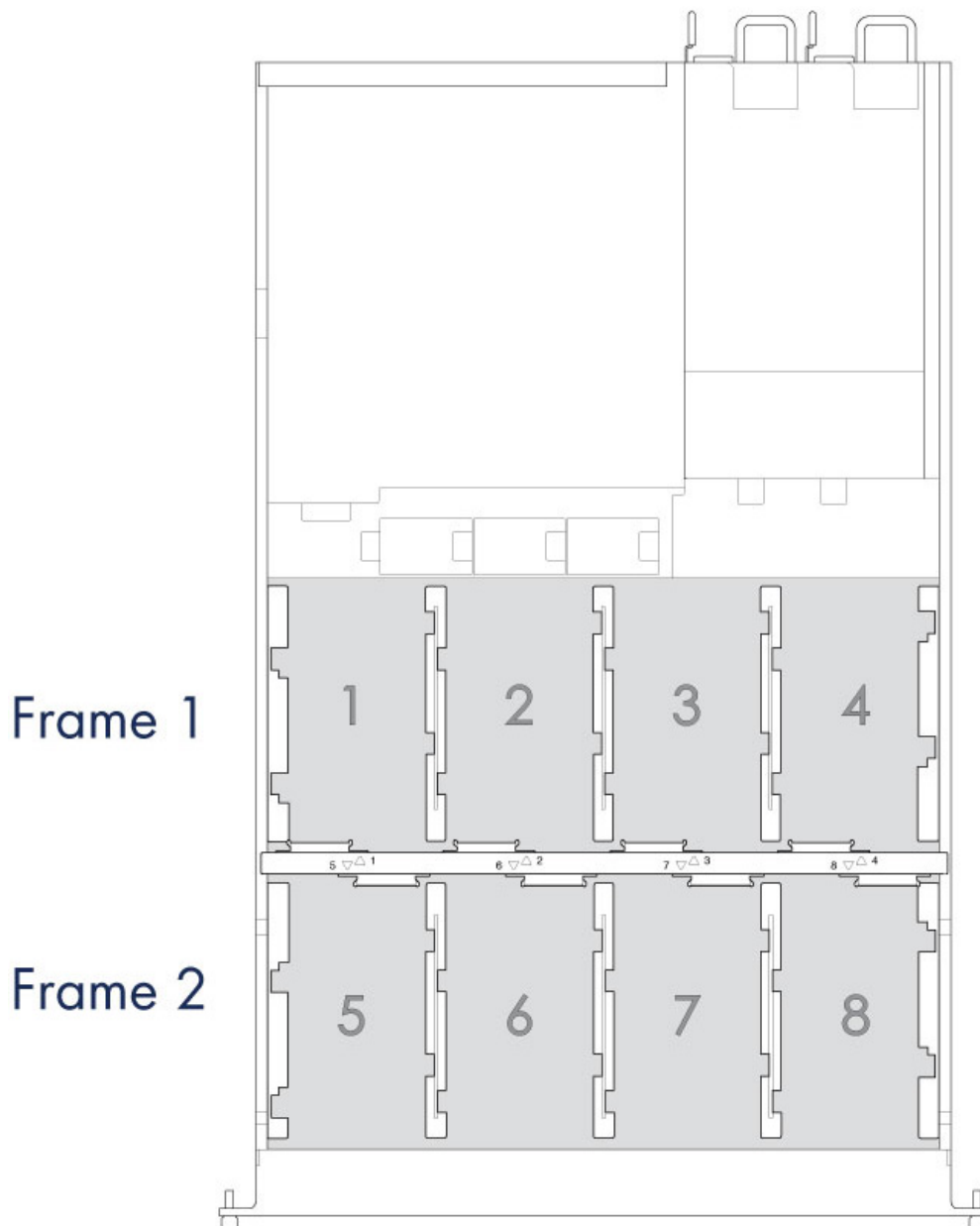

The LaCie 8big Rack Thunderbolt 2 has two hard drive frames, each housing four 3.5-inch hard drives. Each frame has mounting locations for SATA connections.

The hard drive frames provide protection from thermal conduction, radio frequency, and electro-magnetic induction.

Alarm

The LaCie 8big features an alarm that will sound when the the enclosure experiences errors:

- The enclosure temperature is too high
- A fan fails
- A power supply fails
- A disk fails and/or the RAID is broken

The alarm also works in tandem with the identification buttons on the front and rear of the device as well as the identification button in LaCie RAID Manager.

Push the Mute button to turn off the sound for the alarm.

SYSTEM LEDs

The LaCie 8big Rack Thunderbolt 2 LEDs provide information on the system status. Review the illustrations below for the LED locations on the chassis. See [System Overview](#) for further details on each LED.

FRONT

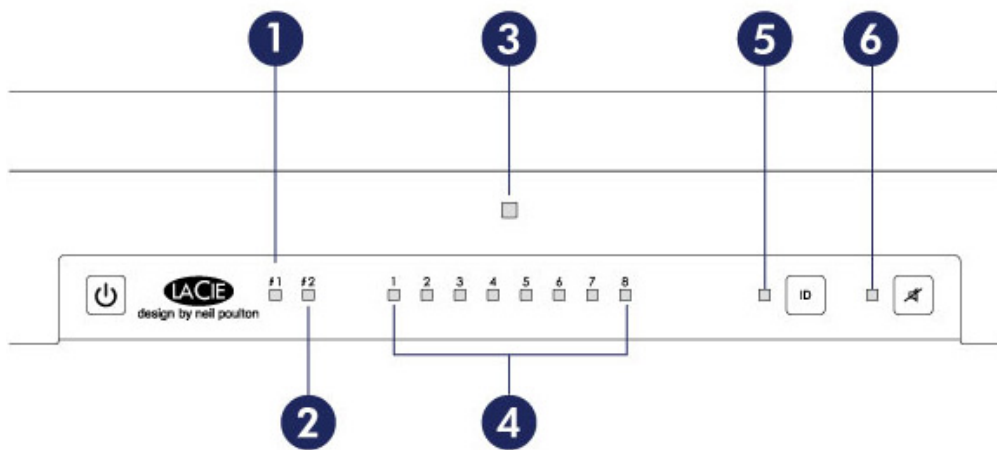

1. Thunderbolt host
2. Thunderbolt daisy chain
3. Status
4. Hard drives
5. Identification
6. Mute

REAR

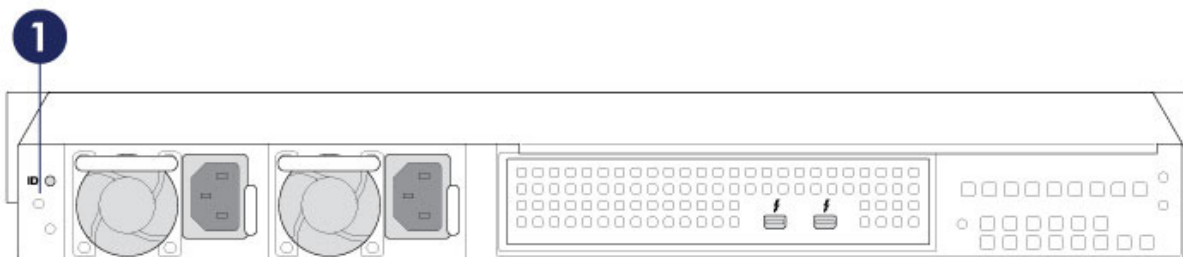

1. Identification LED

INSIDE THE FRONT CHASSIS

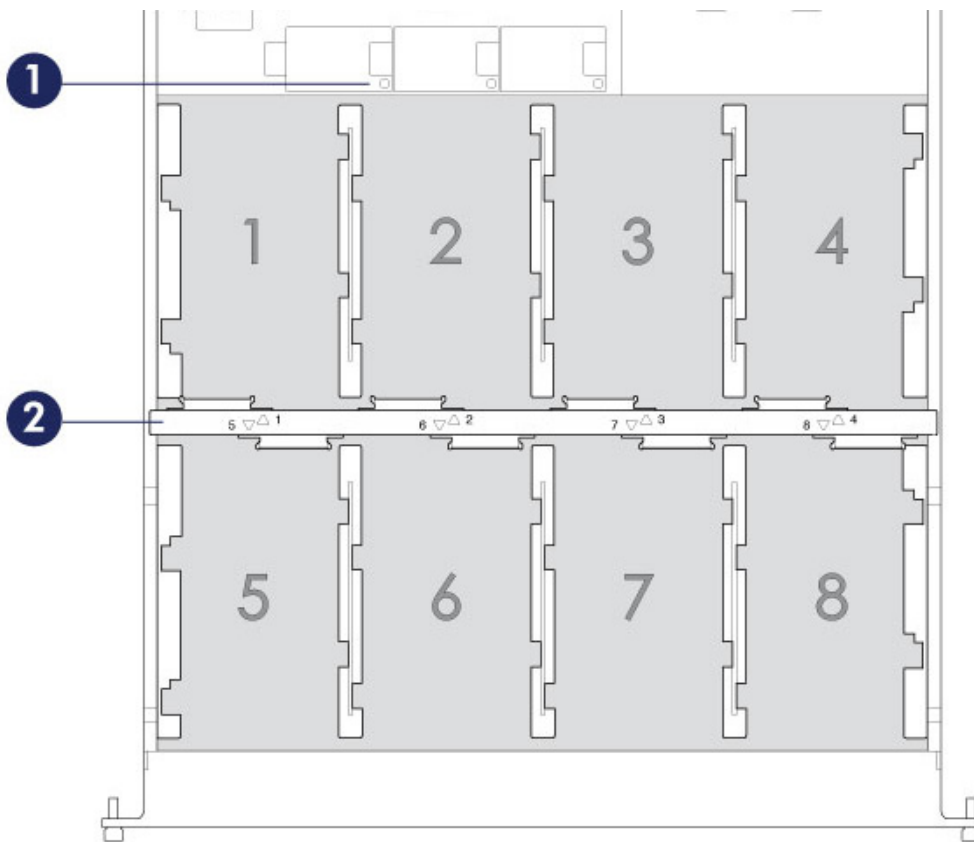

1. Fan LEDs
2. Hard drive LEDs

LED BEHAVIOR

General LED behavior

The list of colors below will help you identify the general status of your LaCie 8big.

Color	State
Solid blue	Ready
Slow blinking blue	Idle mode
Fast blinking blue	Startup and shutdown
Blinking red and blue	RAID synchronization
Blinking red	Warning
Solid red	Error

Status and hard drive LEDs

The status and hard drive LEDs work together to provide up-to-date details on your LaCie 8big's health.

Status LED	Hard drive LEDs	State
Fast blinking blue	Blinking blue	Startup and shutdown
Slow blinking blue	Off	Hard drives have spun down and the Thunderbolt ports are in idle mode, allowing for daisy chain
Solid blue	Solid blue	The DAS is ready.
Solid blue	Blinking blue for working hard drives	The hard drives are being accessed (read/write).
Blinking blue/red	Blinking blue/red	RAID synchronizing
Blinking red	Solid red for non-functional hard drives	RAID is degraded. Data remains intact but the array is no longer protected should another hard drive fail.
Blinking red	Blinking red on a hard drive	Hard drive warning. A hard drive may be experiencing errors or, it is about to fail.
Solid red	Solid red for a non-functional or failed hard drive	One or more hard drives have failed and the RAID is broken. Data is lost.
Blinking red	Blue	Temperature alert; a power supply is failing
Solid red	Blue	Temperature is critical. A critical state is accompanied by an audible alert.
Solid red	Solid or blinking blue	One or more fans are not spinning.

Thunderbolt 2 ports, identification, and mute LEDs

Thunderbolt 2

Behavior	State
Solid blue on the Thunderbolt 2 host LED	The Thunderbolt 2 port is connected to a computer.
Solid blue on the Thunderbolt 2 daisy chain LED	The LaCie 8big is connected to a daisy chain of Thunderbolt devices and/or displays.

Identification

Front Identification LED Behavior	Rear Identification LED Behavior	State
Blinking amber	Blinking amber	An identification button has been pushed (front or rear).
Off	The identification feature is off.	

Mute

Behavior	State
Solid amber	The mute button has been pushed to turn off an audible alert or, to stop the unit from sounding an audible alert.
Off	The mute feature is off.

Hard drive and fan LEDs (inside the front chassis)

Hard drives

Behavior	State
Solid blue	The hard drives are ready.
Blinking blue	The hard drives are being accessed (read/write).
Blinking blue/red	RAID synchronizing or firmware update.
Blinking red on a single hard drive	Warning that the hard drive may be failing.
Blinking red on multiple hard drives	Warning that the RAID may be failing.
Solid red on a single hard drive	The hard drive has failed.
Solid red on multiple hard drives	The RAID has failed.
Off on hard drive slots within the chassis	A hard drive has not been plugged into the slot's SATA connection or it is not receiving power.

Fans

Behavior	State
Solid blue	The fan is working.
Solid red	The fan has failed.

SETTING UP - MAC

The LaCie 8big Rack Thunderbolt 2 is shipped with the following installation components:

- Rack rail kit for a standard 19-inch rack
 - Inner rack rails (A1, A2)
 - Outer rack rails (B1, B2)
- Screws and washers for the rack rails
 - Inner rack rail M4x4 screws (8)
 - Outer rack rail M5x10 screws (8)
 - Washers (8)
- Cable management arm kit
- Power supply cables (certain models are shipped with one power supply cable)
- Thunderbolt cable (2m)
- Hard drives (the amount of hard drives can vary by model)
- LaCie 8big Rack Thunderbolt 2 enclosure

An additional plastic bag with screws has been provided to fasten hard drives to the hard drive drawers. If you must secure hard drives to the hard drive trays, make certain to use the included screws.

The instructions below are also available on the Quick Start Guide included with the LaCie 8big.

BEFORE INSTALLATION: CHOOSE COMPATIBLE HARD DRIVES

If your LaCie 8big shipped with eight hard drives, you can skip this section and move to Step 1. If your LaCie 8big shipped with empty hard drive slots, consider the following:

- When adding new hard drives to empty slots, LaCie highly recommends using hard drives that have been tested and approved for the LaCie 8big. For a list of compatible hard drives, visit [LaCie 8big Rack Thunderbolt 2 hard drives](#).
- LaCie cannot guarantee performance or functionality when using hard drives that do not appear on the list of compatible hard drives.

STEP 1 - DOWNLOAD AND INSTALL LACIE RAID MANAGER

Important info regarding LaCie RAID Manager and LaCie Desktop Manager: Older versions of LaCie Desktop Manager may conflict with LaCie RAID Manager. If you are using LaCie Desktop Manager, go to [LaCie support](http://www.lacie.com/support) to download and install the latest version. It is recommended that you install the new version before following the steps below.

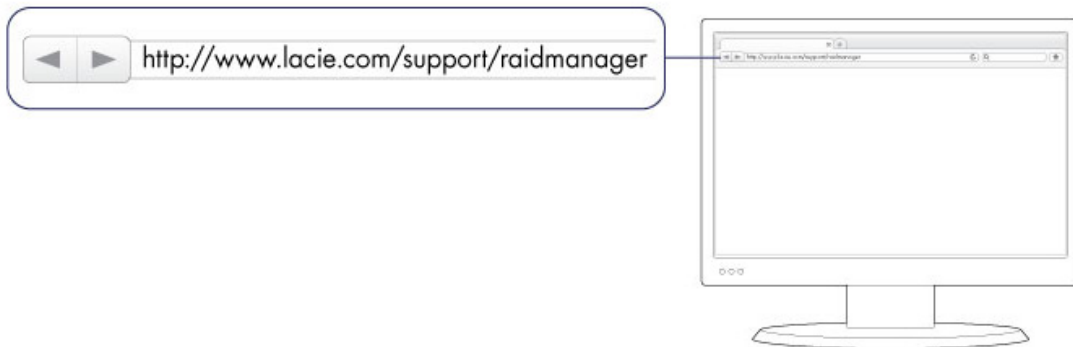

The software utility LaCie RAID Manager gives you:

- The driver to mount the LaCie 8big storage
- LaCie RAID Manager to monitor and manage the storage

The LaCie 8big hard drives are preconfigured as RAID 5 and formatted for Mac (HFS+). Use LaCie RAID Manager to confirm the health of the hard drives or to change the RAID configuration:

1. Download the installer at <http://www.lacie.com/support/raidmanager/>.
2. Launch the installer on the computer that will connect to the LaCie 8big.
3. Follow the on-screen instructions to complete the installation.

STEP 2 - RACK RAILS

1. Attach the inner rack rails to the LaCie 8big using four screws on each side.

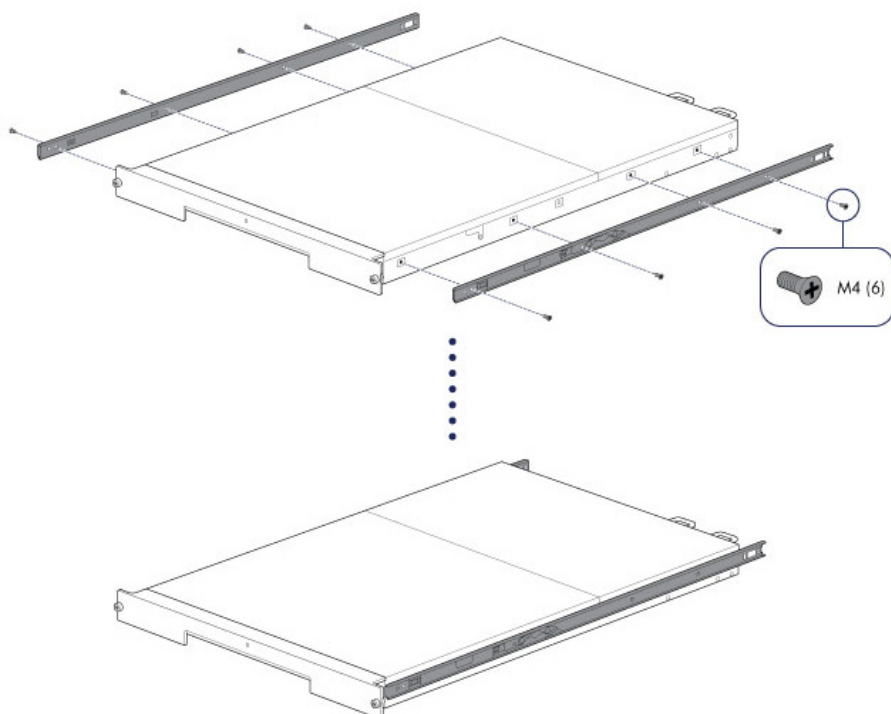

2. Attach the outer rack rails to the rack. If necessary, unlock the rear screws on the outer rack rails to extend the sliding brackets.

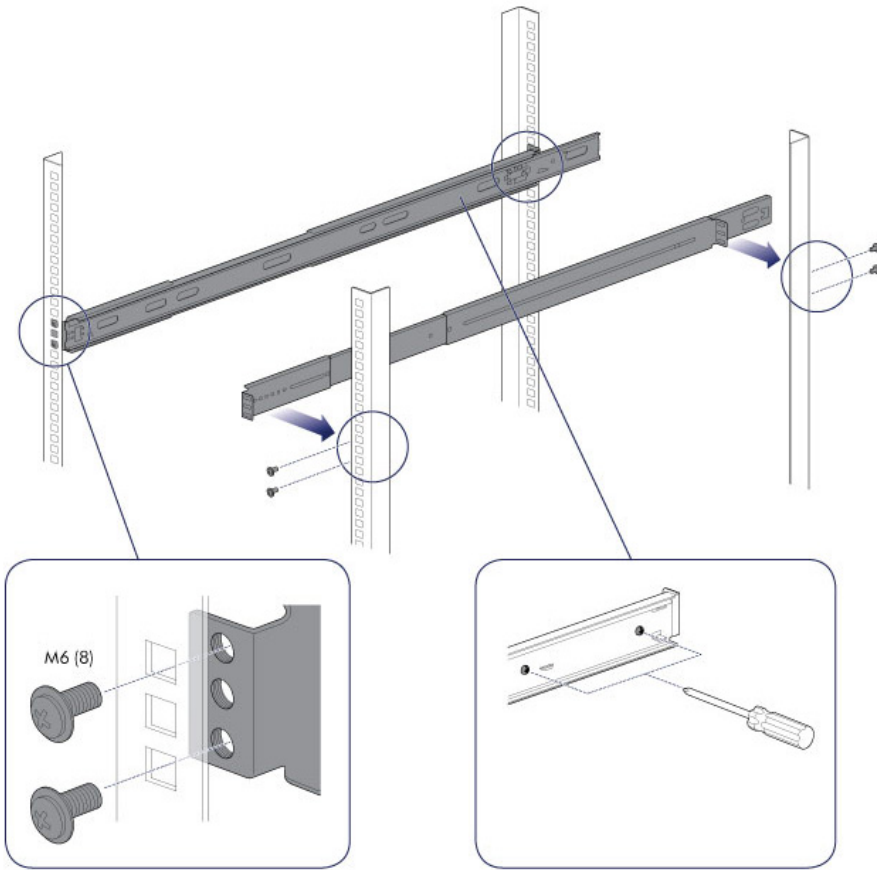

3. Slide the LaCie 8big into the rack. To unlock the rails, pull the rail fasteners on each side toward you. An audible click indicates that the LaCie 8big is securely fastened to the rack.

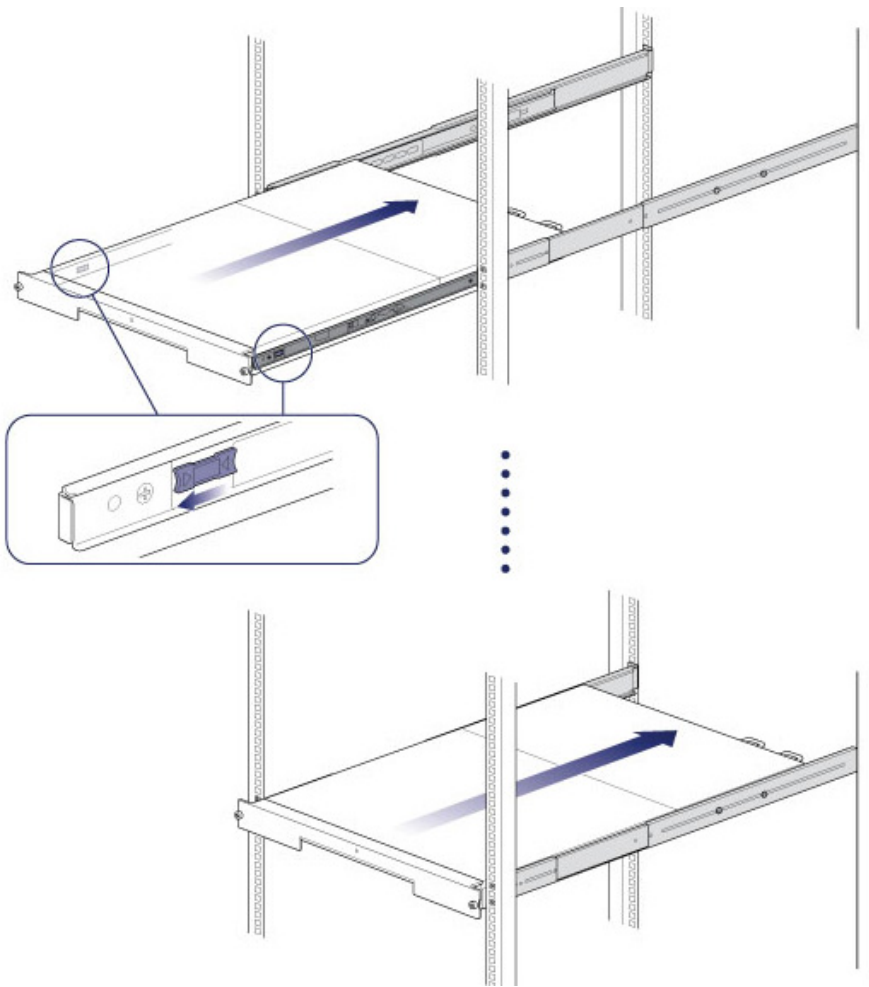

STEP 3 - CABLE MANAGEMENT ARM

Attach the cable management arm to the back of the rack rails.

1. Snap the right outer connection into the outside rail.

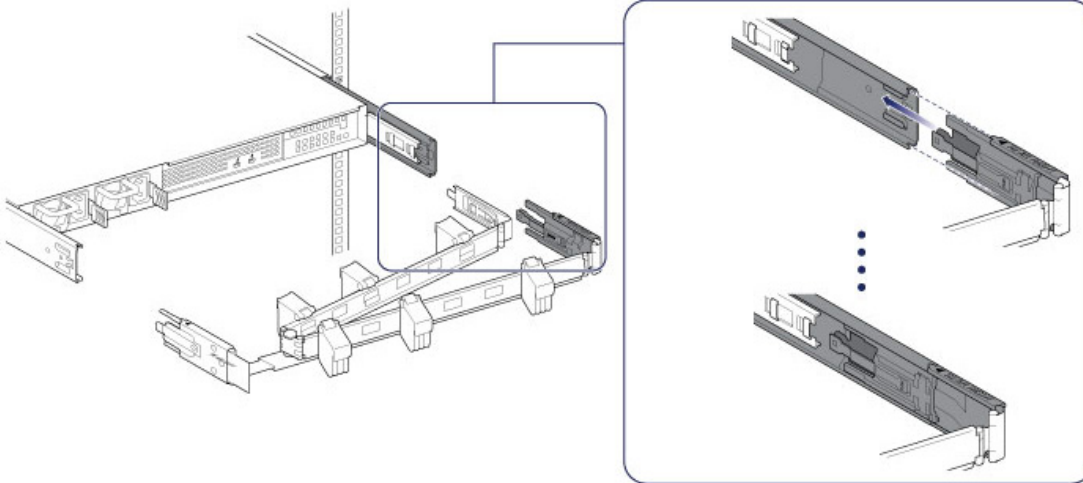

2. Snap the left connection into the outside rail.

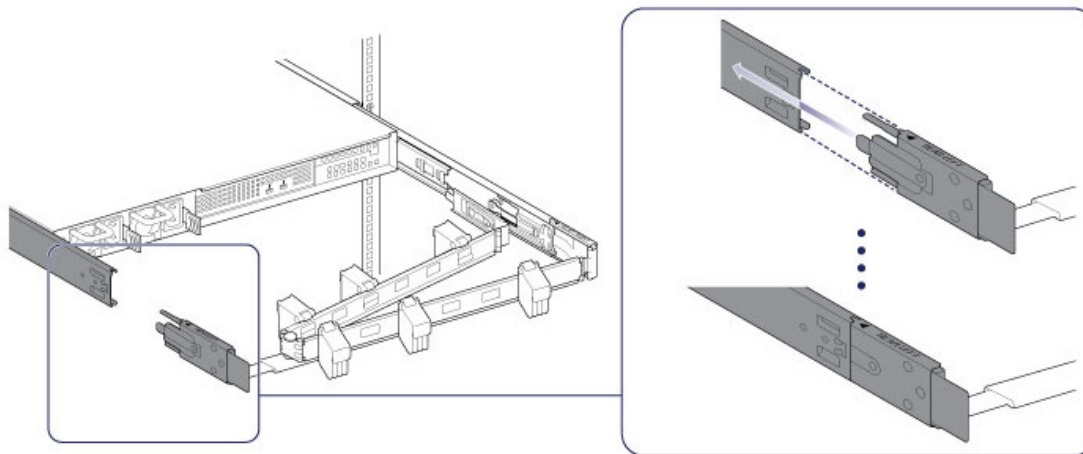

3. Guide the right inner connection into the inner rack rail.

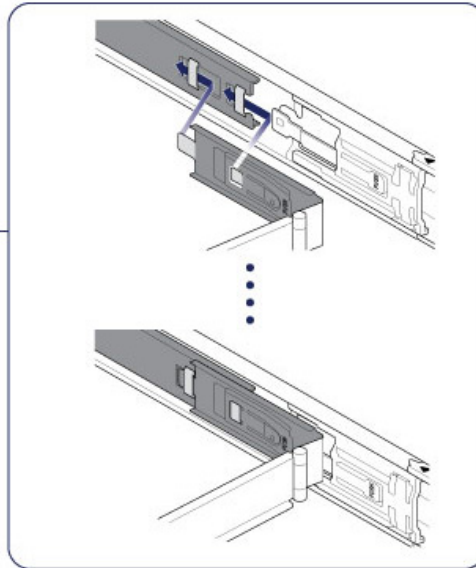
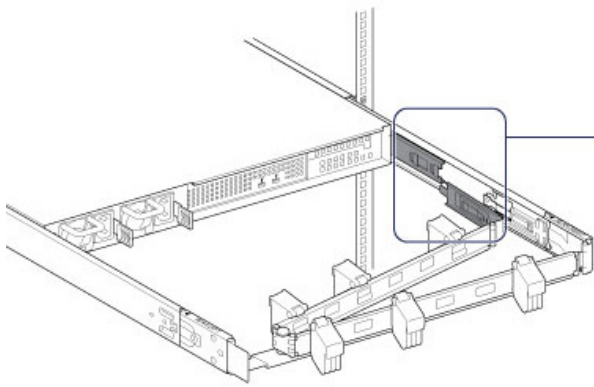

STEP 4 - CABLES

Connections

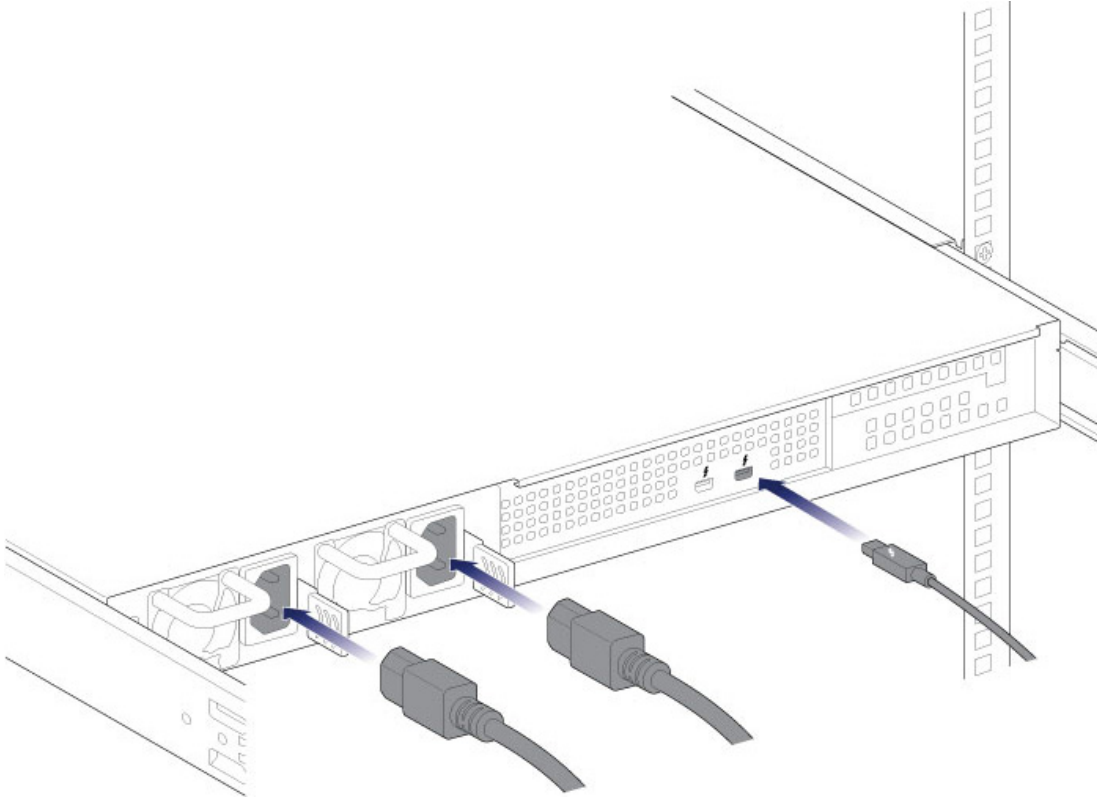

- Thunderbolt cable
- Power cables

Note regarding a Thunderbolt daisy chain: You can also connect a second Thunderbolt cable to daisy chain compatible devices to the LaCie 8big. A Thunderbolt daisy chain supports up to seven devices, including the computer. See [Daisy Chain](#) for further information.

Notes on power supplies: Certain LaCie 8big models are shipped with one power supply, which is sufficient for normal operation. LaCie 8big models shipped with two power supplies offer redundancy in case one should fail. When inserting two power supplies into the LaCie 8big, make certain to plug them both into active power supplies. The enclosure will sound the alarm if it senses two power supplies but only one is connected to an active power supply.

Placement

1. Open the panels on the cable management arm and thread the cables. Allow slack for external connections and sliding the LaCie 8big on its rails.

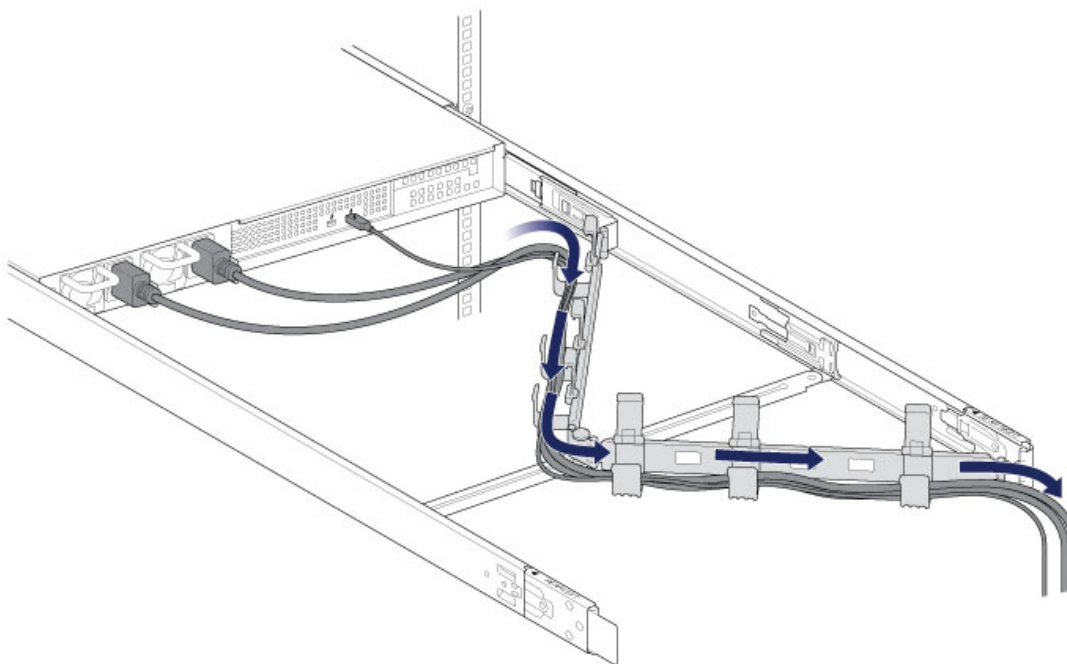

2. Close the panels.

STEP 5 - HARD DRIVES

Remove the cover

1. Slide the LaCie 8big toward you until it locks into position.

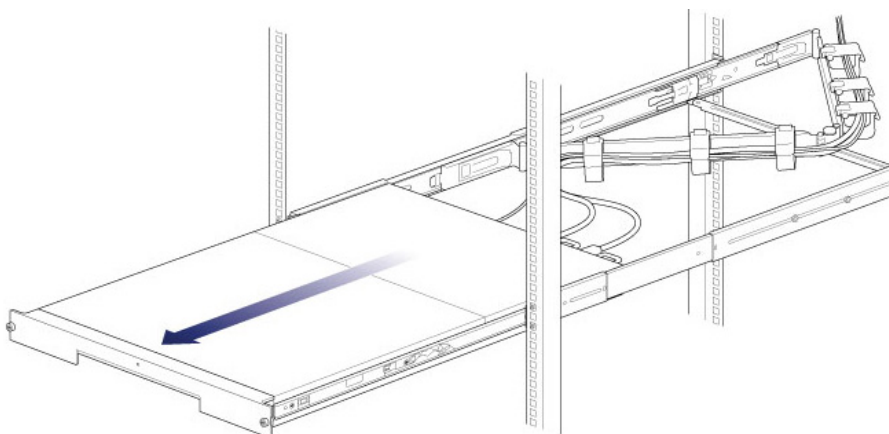

2. Release the cover by simultaneously pushing both front latches toward you.

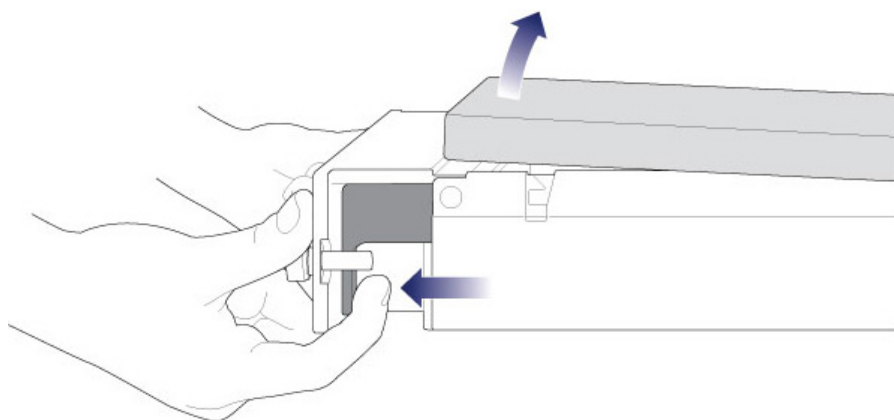

3. Lift the cover.

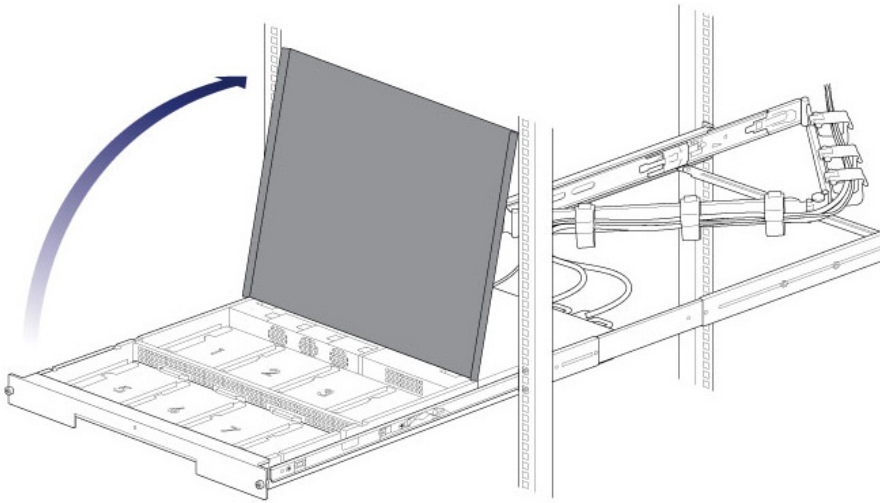

Insert the hard drives

Important info: Make certain that you are properly grounded before touching the hard drives.

1. Push the hard drive's lock button to open the latch.

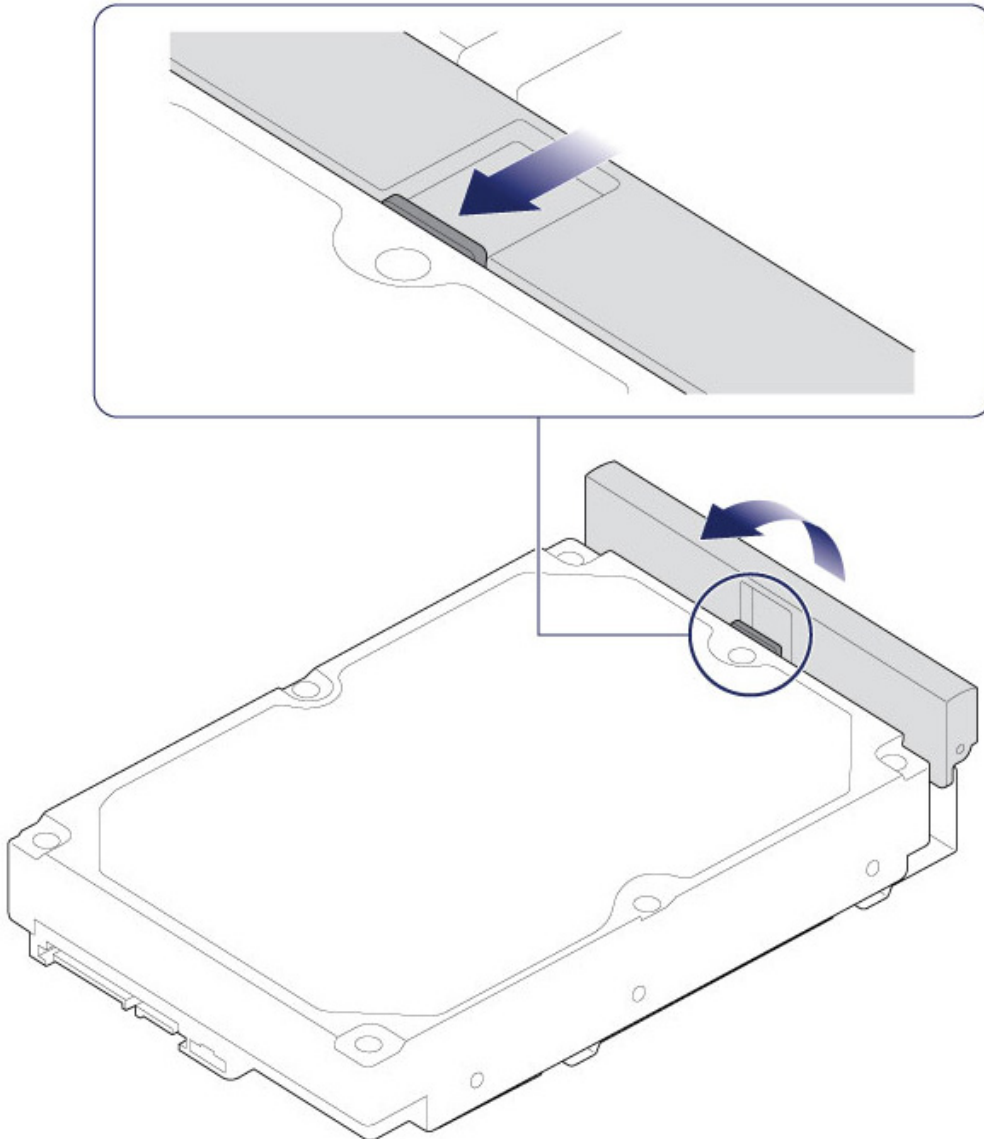

2. Place the hard drive on the LaCie 8big's hard drive guides. Confirm that the hard drive is correctly aligned on the guides by gently pushing it away from the SATA connection.

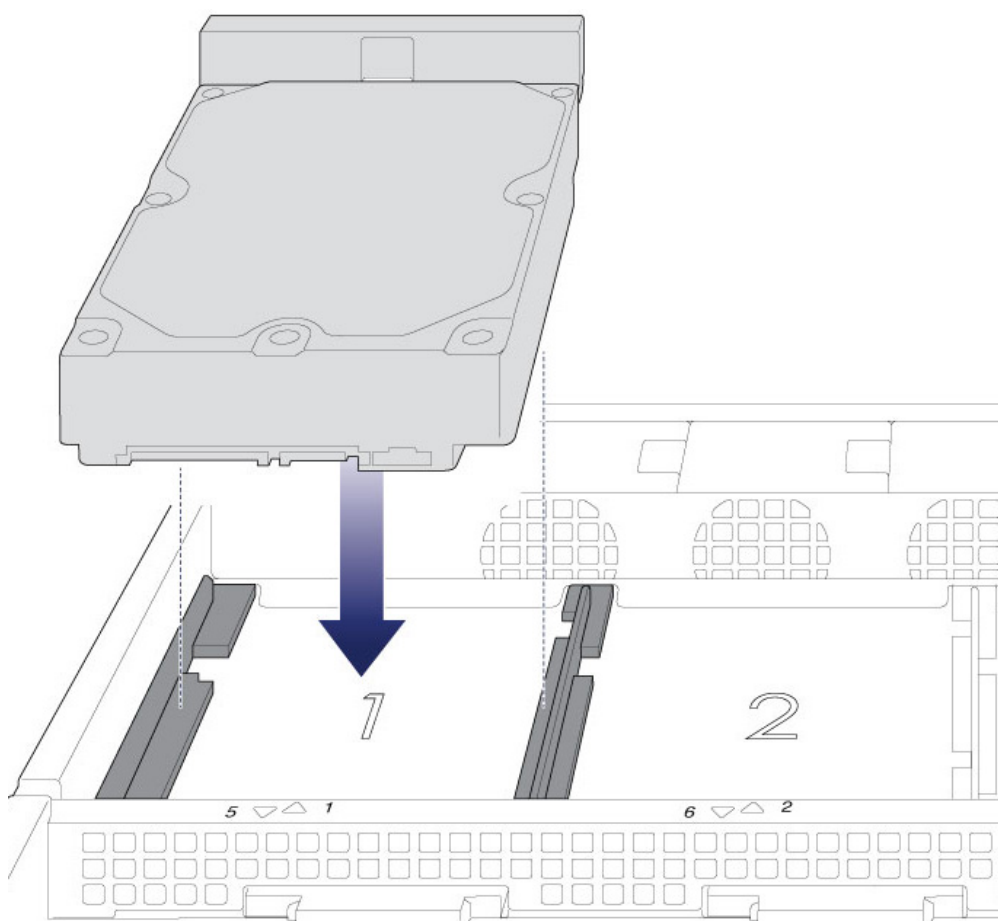

3. Slide the hard drive into the SATA connection.

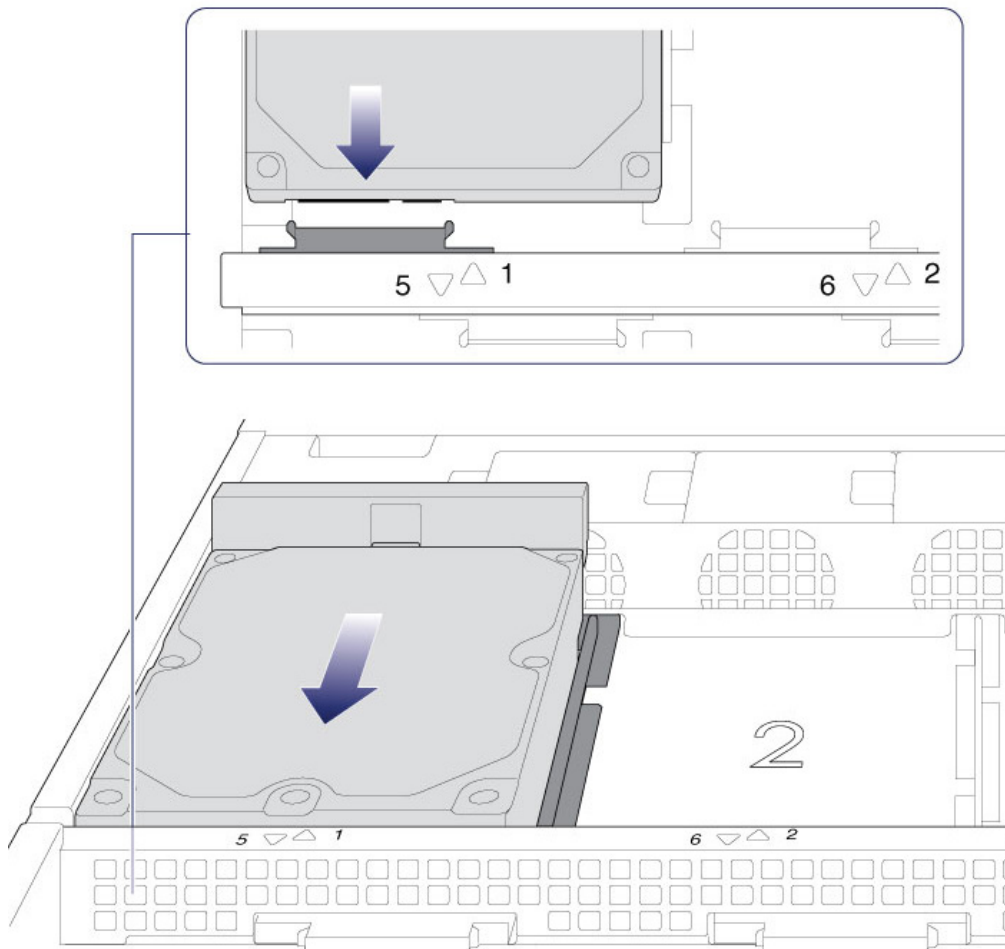

4. Close the hard drive's latch.

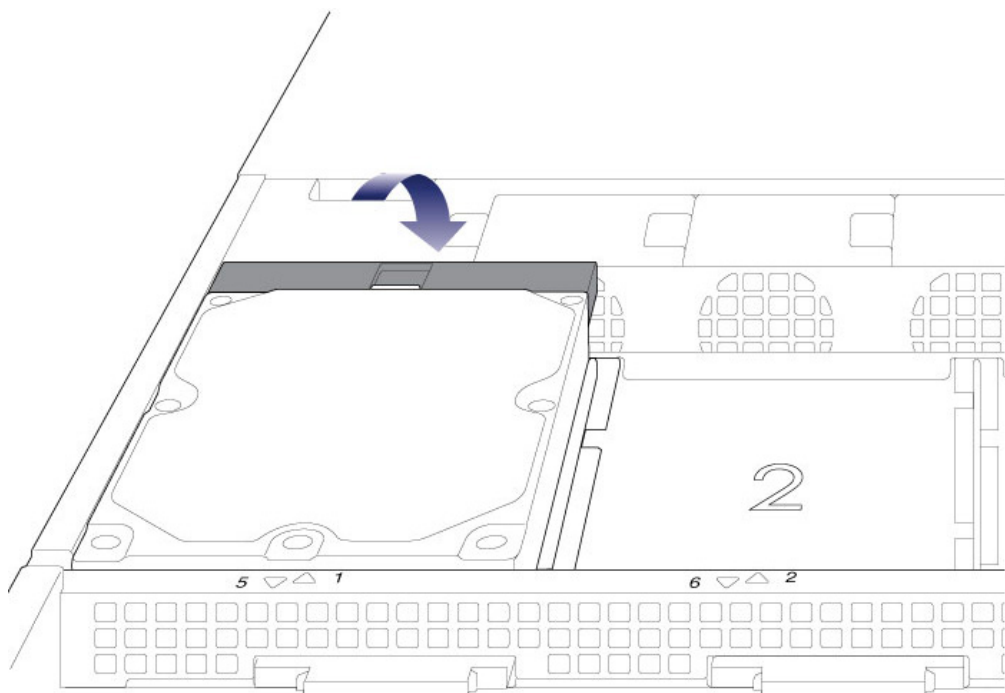

5. Repeat the steps for each hard drive.
6. Close the cover and slide the LaCie 8big into the rack. To unlock the rails, pull the rail fasteners on each side toward you. Secure the LaCie 8big to the rack using the two front screws.

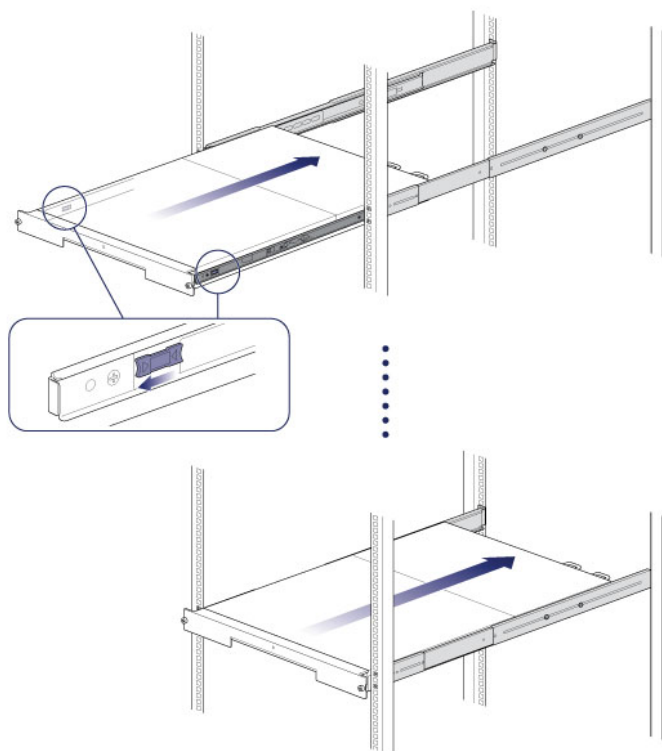

Step 6 - Computer and power connections

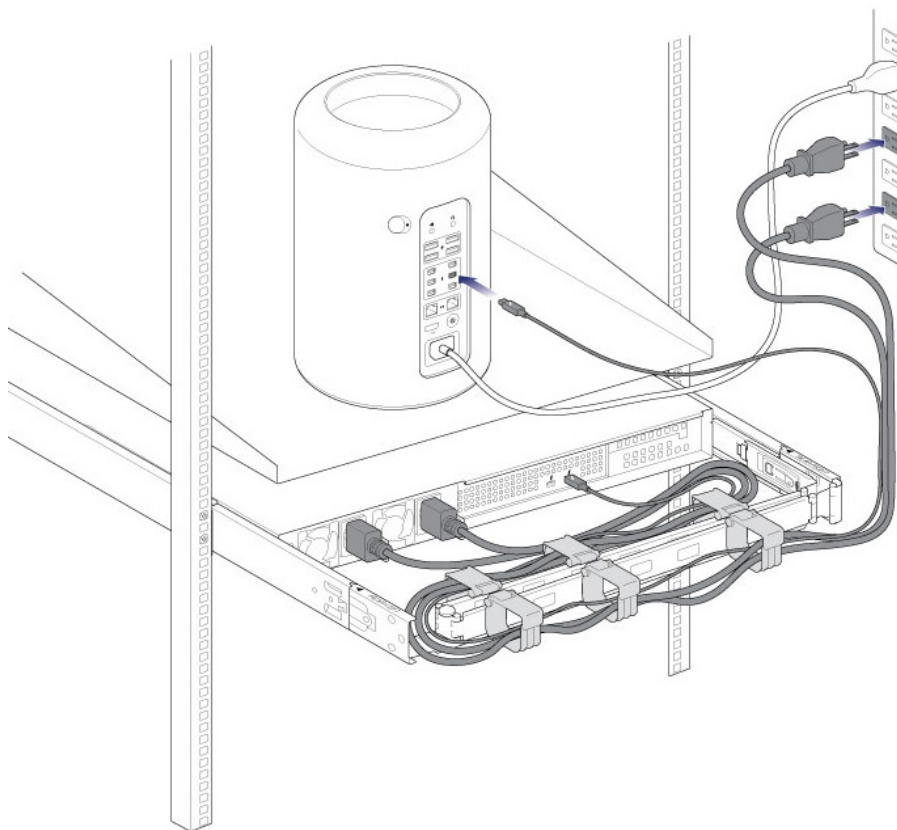

1. Connect the power cables to active outlets.
2. Connect the Thunderbolt cable to your computer.

STEP 5 - START THE HARD DRIVES

1. Apply a short push to the power button. See [Operation](#) for details on how to use the power button.

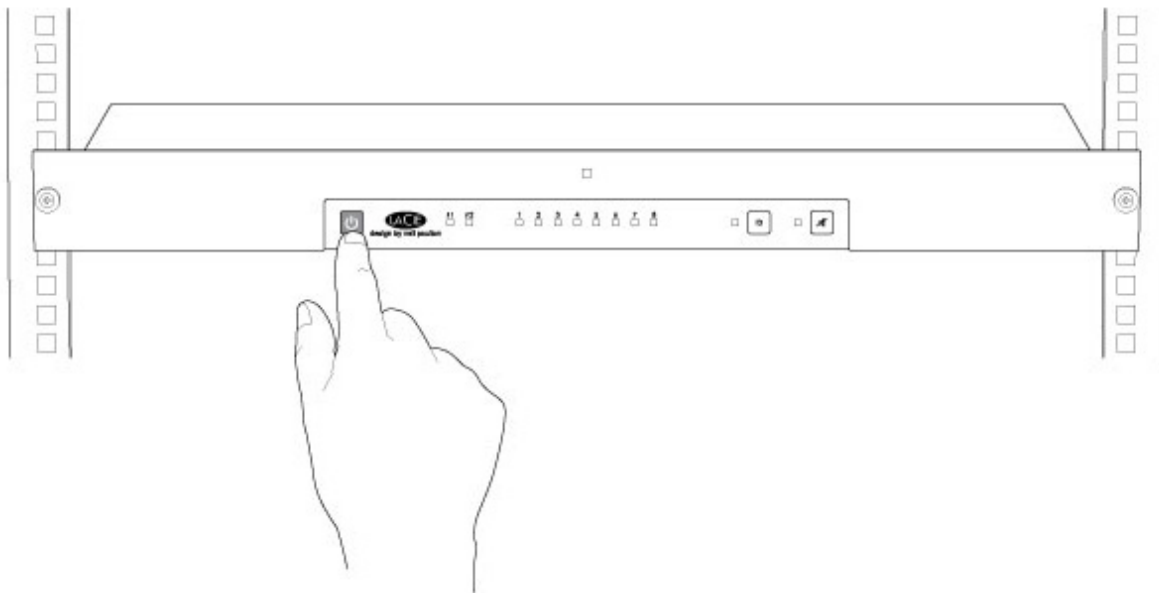

See the [LaCie RAID Manager User Manual](#) for instructions on how to manage the hard drives.

SETTING UP - WINDOWS

The LaCie 8big Rack Thunderbolt 2 is shipped with the following installation components:

- Rack rail kit for a standard 19-inch rack
 - Inner rack rails (A1, A2)
 - Outer rack rails (B1, B2)
- Screws and washers for the rack rails
 - Inner rack rail M4x4 screws (8)
 - Outer rack rail M5x10 screws (8)
 - Washers (8)
- Cable management arm kit
- Power supply cables (certain models are shipped with one power supply cable)
- Thunderbolt cable (2m)
- Hard drives (the amount of hard drives can vary by model)
- LaCie 8big Rack Thunderbolt 2 enclosure

An additional plastic bag with screws has been provided to fasten hard drives to the hard drive drawers. If you must secure hard drives to the hard drive trays, make certain to use the included screws.

The instructions below are also available on the Quick Start Guide included with the LaCie 8big.

BEFORE INSTALLATION: CHOOSE COMPATIBLE HARD DRIVES

If your LaCie 8big shipped with eight hard drives, you can skip this section and move to Step 1. If your LaCie 8big shipped with empty hard drive slots, consider the following:

- When adding new hard drives to empty slots, LaCie highly recommends using hard drives that have been tested and approved for the LaCie 8big. For a list of compatible hard drives, visit [LaCie 8big Rack Thunderbolt 2 hard drives](#).
- LaCie cannot guarantee performance or functionality when using hard drives that do not appear on the list of compatible hard drives.

STEP 2 - RACK RAILS

1. Attach the inner rack rails to the LaCie 8big using four screws on each side.

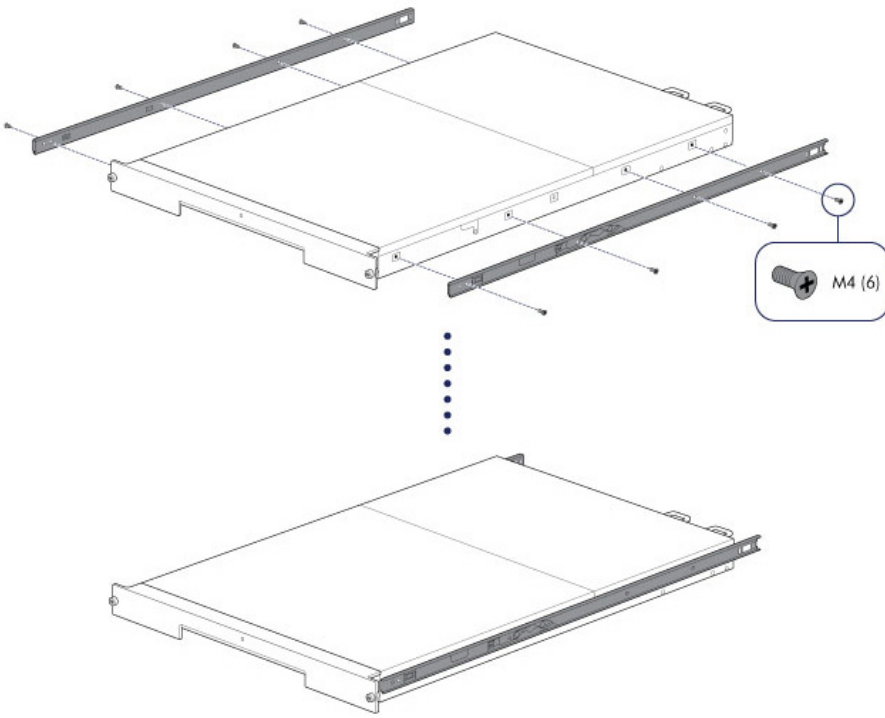

2. Attach the outer rack rails to the rack. If necessary, unlock the rear screws on the outer rack rails to extend the sliding brackets.

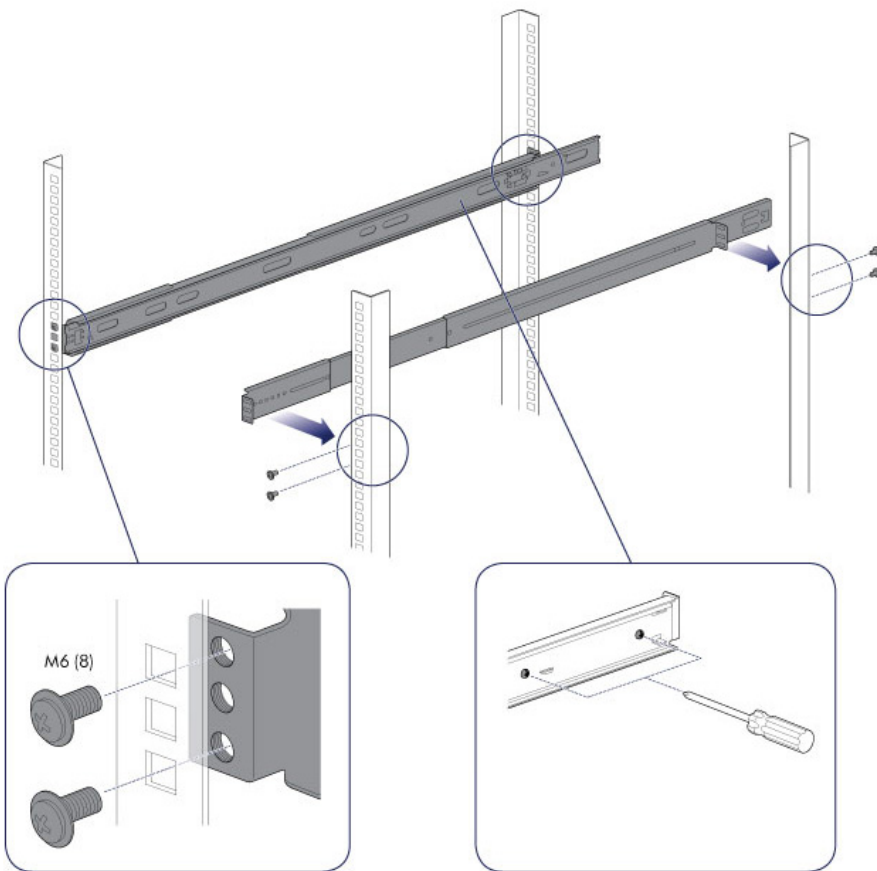

3. Slide the LaCie 8big into the rack. To unlock the rails, pull the rail fasteners on each side toward you. An audible click indicates that the LaCie 8big is securely fastened to the rack.

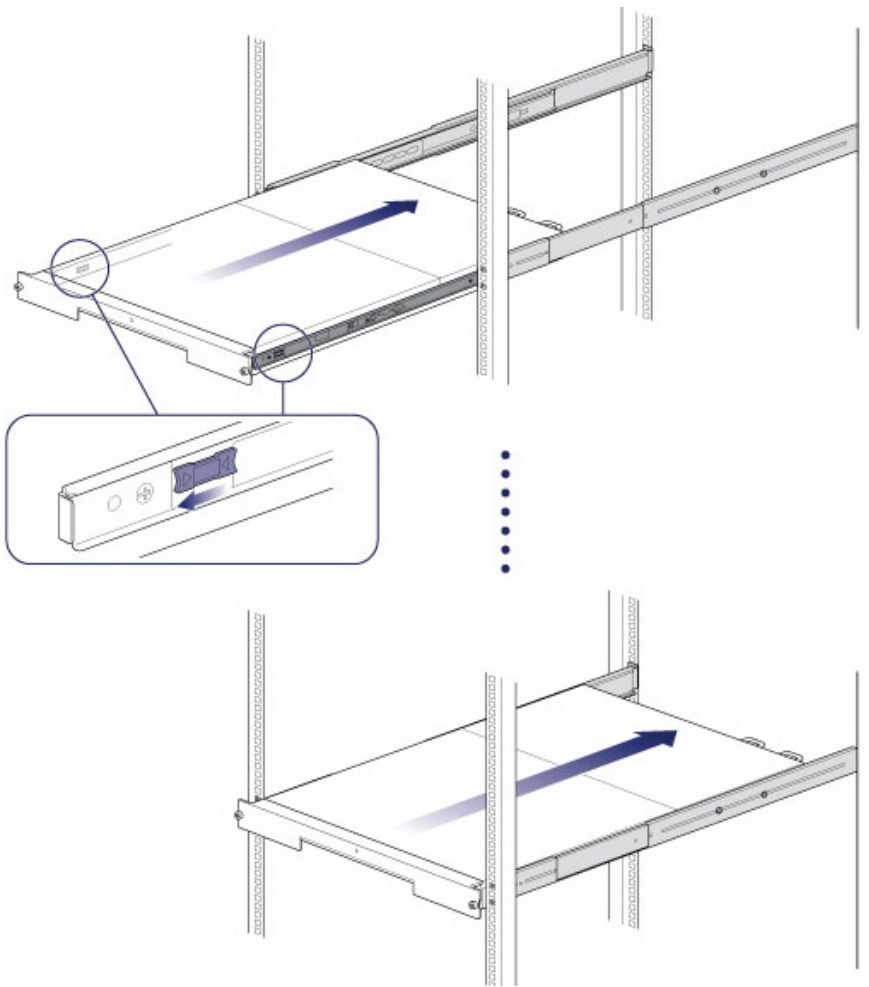

STEP 3 - CABLE MANAGEMENT ARM

Attach the cable management arm to the back of the rack rails.

1. Snap the right outer connection into the outside rail.

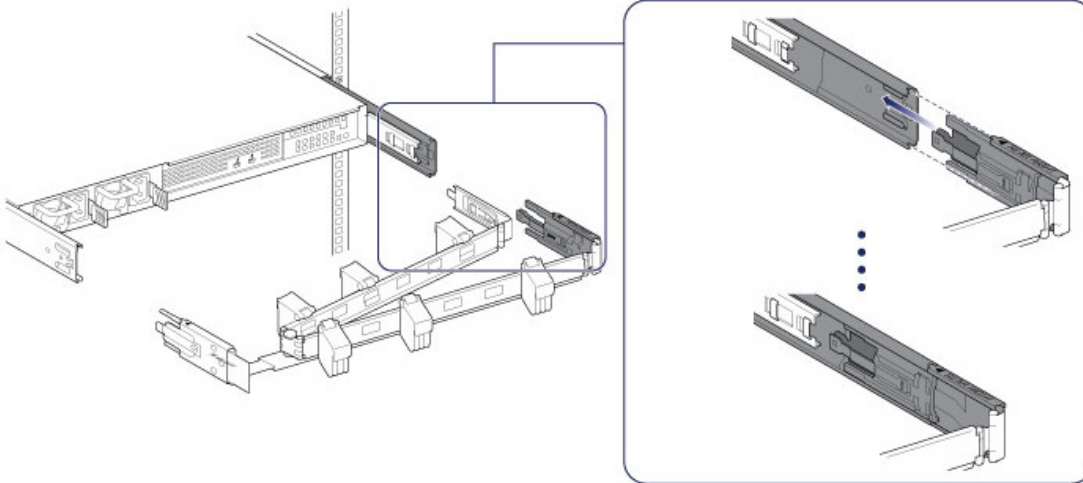

2. Snap the left connection into the outside rail.

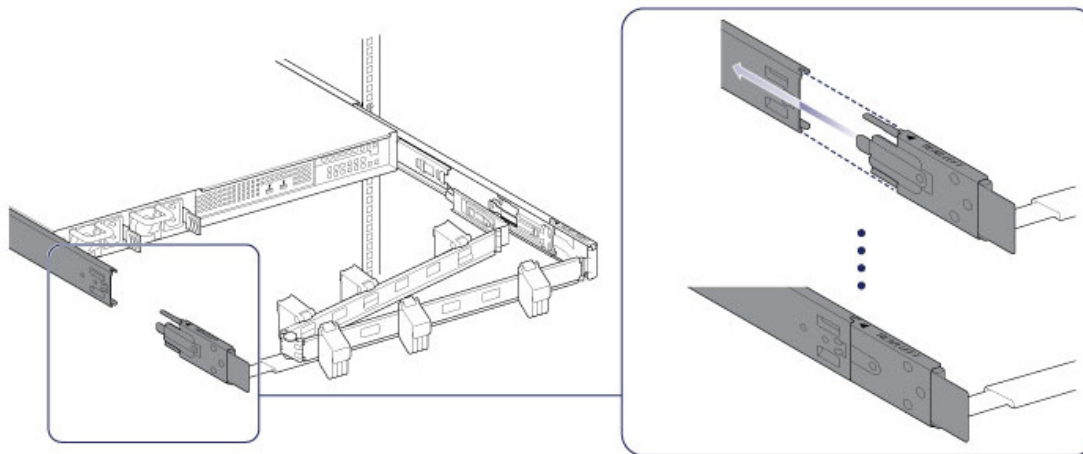

3. Guide the right inner connection into the inner rack rail.

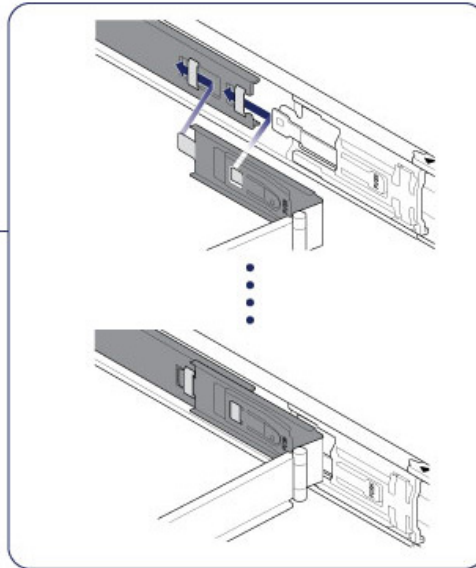
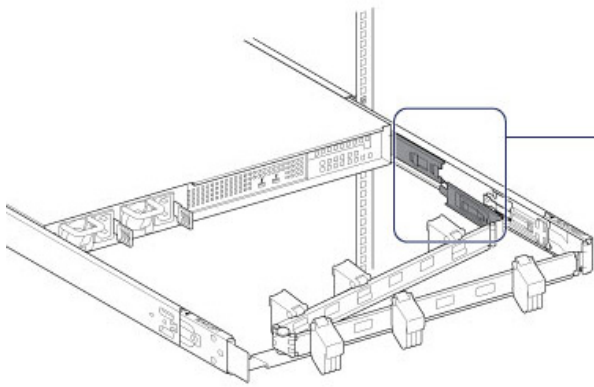

STEP 4 - CABLES

Connections

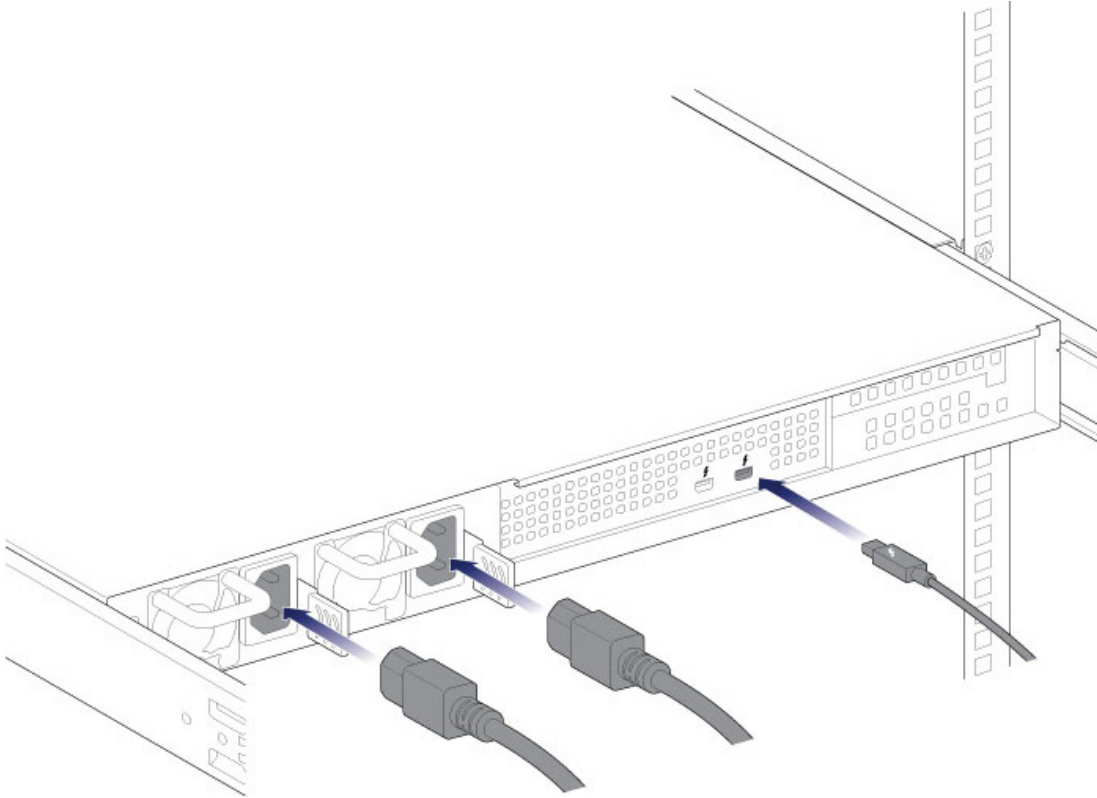

- Thunderbolt cable
- Power cables

Note regarding a Thunderbolt daisy chain: You can also connect a second Thunderbolt cable to daisy chain compatible devices to the LaCie 8big. A Thunderbolt daisy chain supports up to seven devices, including the computer. See [Daisy Chain](#) for further information.

Notes on power supplies: Certain LaCie 8big models are shipped with one power supply, which is sufficient for normal operation. LaCie 8big models shipped with two power supplies offer redundancy in case one should fail. When inserting two power supplies into the LaCie 8big, make certain to plug them both into active power supplies. The enclosure will sound the alarm if it senses two power supplies but only one is connected to an active power supply.

Placement

1. Open the panels on the cable management arm and thread the cables. Allow slack for external connections and sliding the LaCie 8big on its rails.

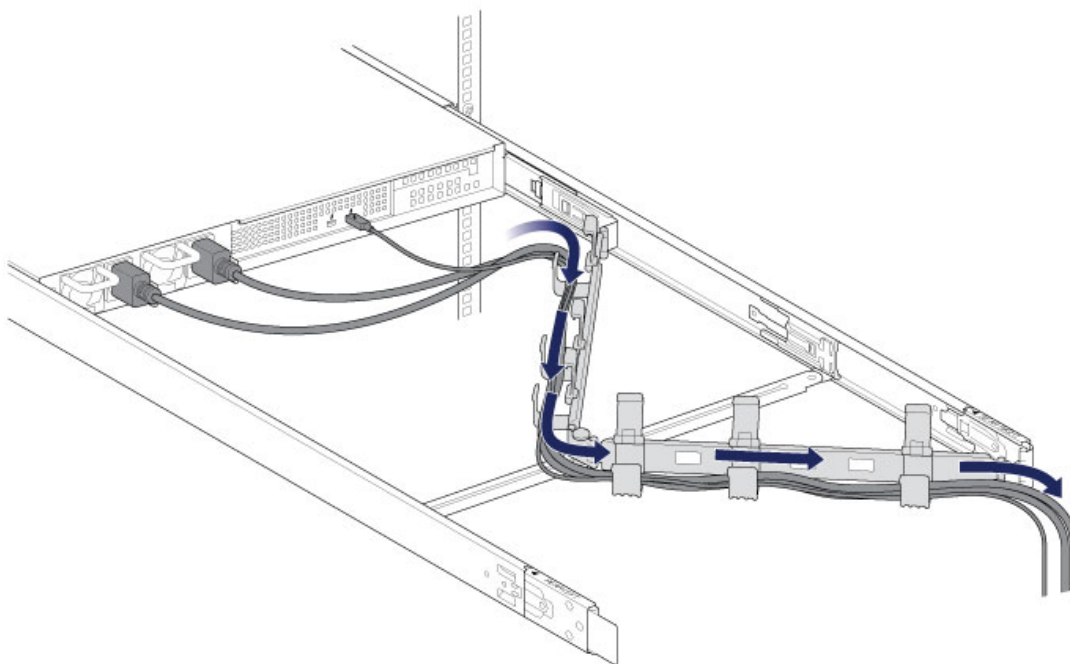

2. Close the panels.

STEP 5 - HARD DRIVES

Remove the cover

1. Slide the LaCie 8big toward you until it locks into position.

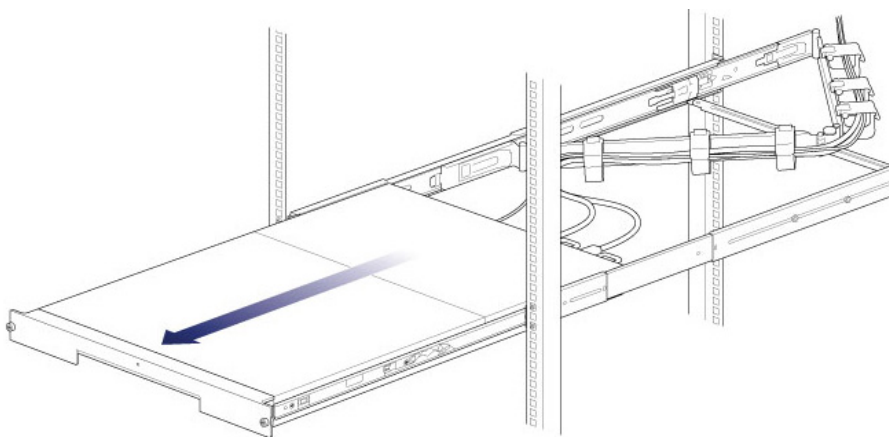

2. Release the cover by simultaneously pushing both front latches toward you.

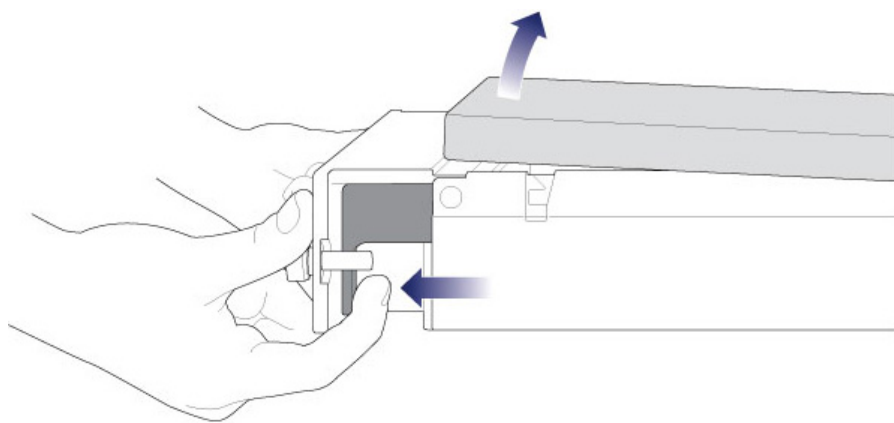

3. Lift the cover.

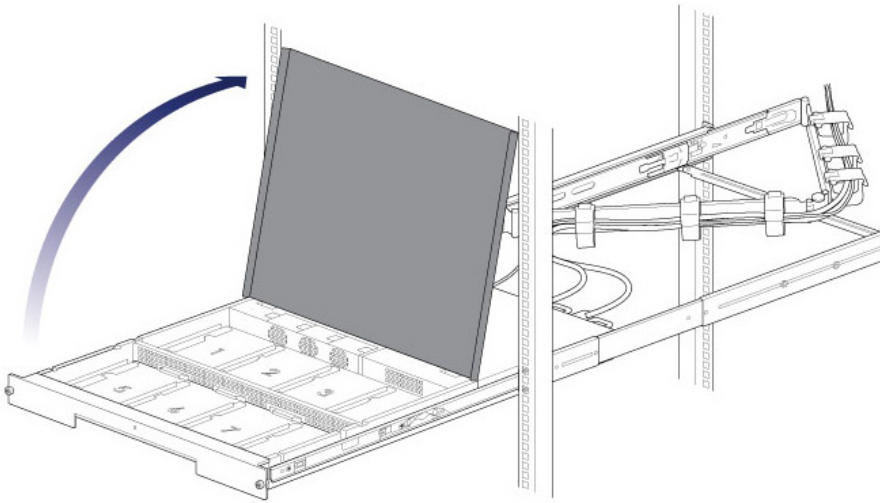

Insert the hard drives

Important info: Make certain that you are properly grounded before touching the hard drives.

1. Push the hard drive's lock button to open the latch.

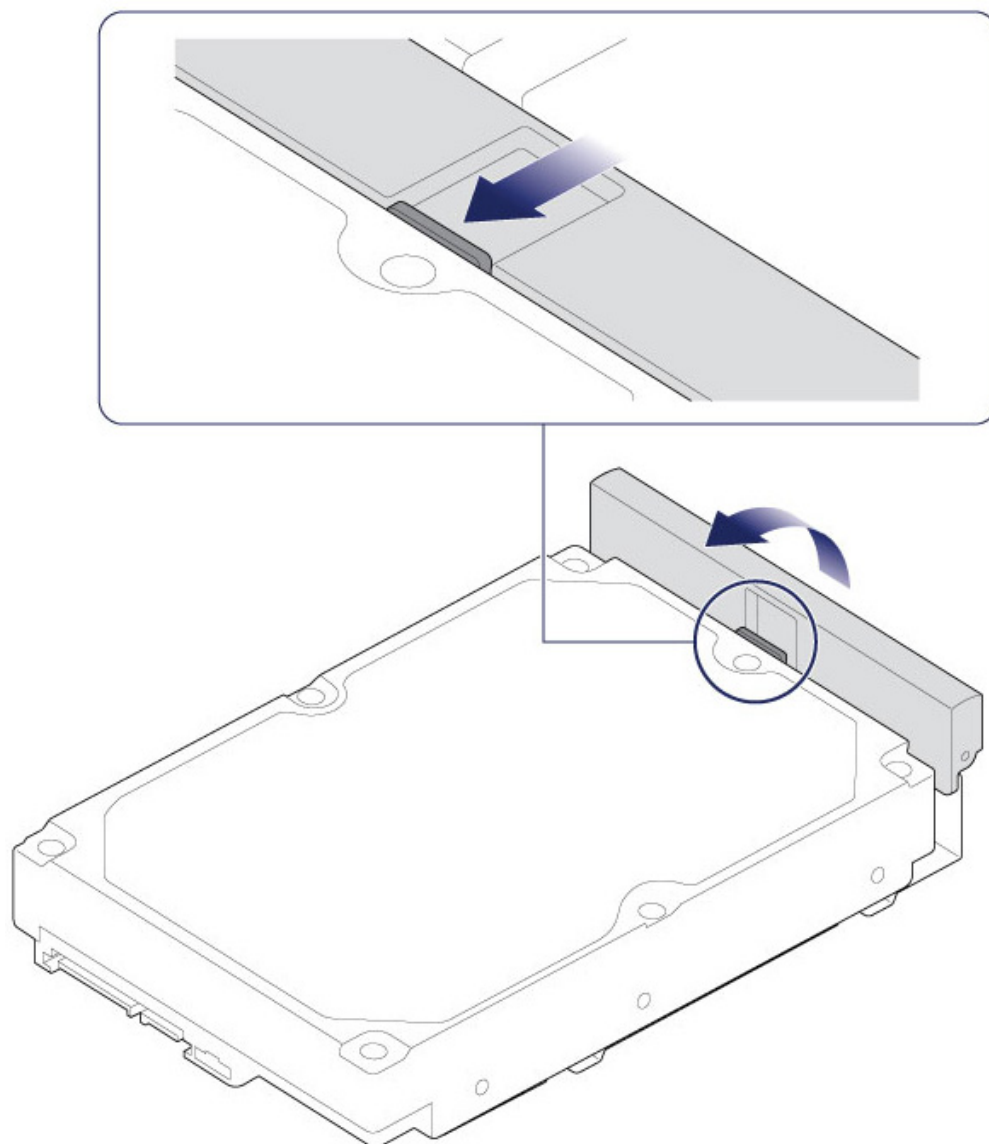

2. Place the hard drive on the LaCie 8big's hard drive guides. Confirm that the hard drive is correctly aligned on the guides by gently pushing it away from the SATA connection.

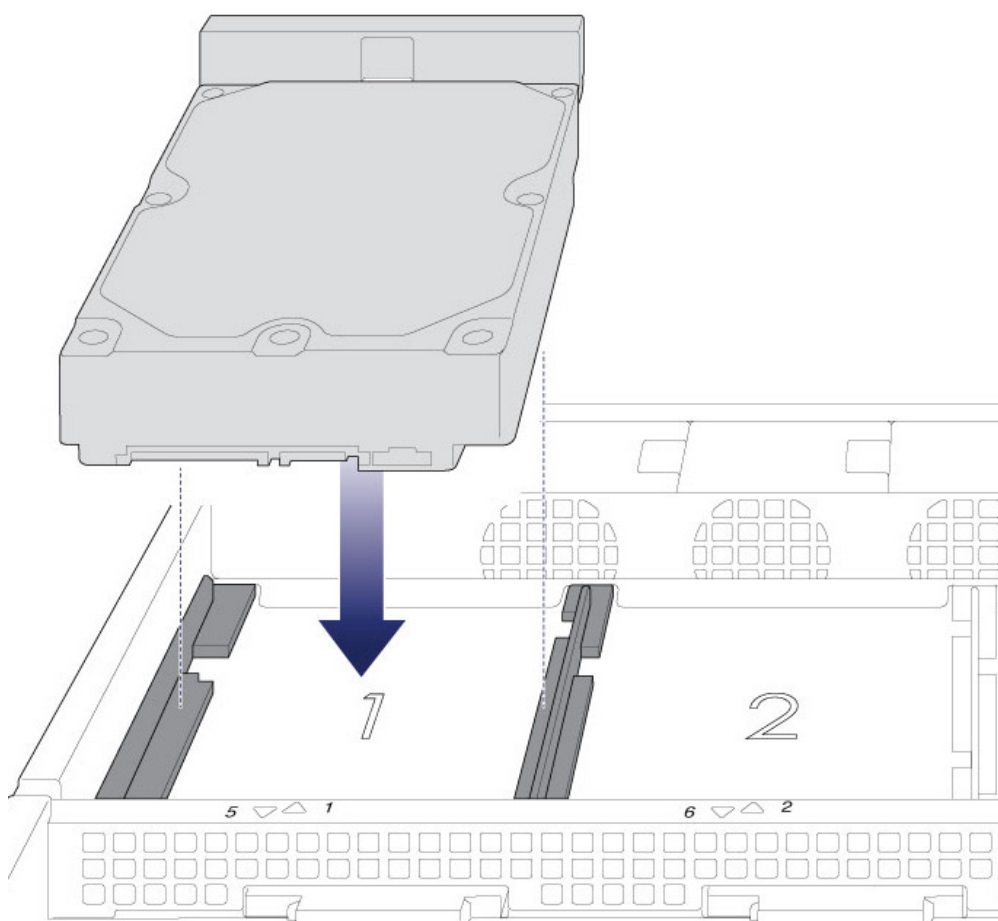

3. Slide the hard drive into the SATA connection.

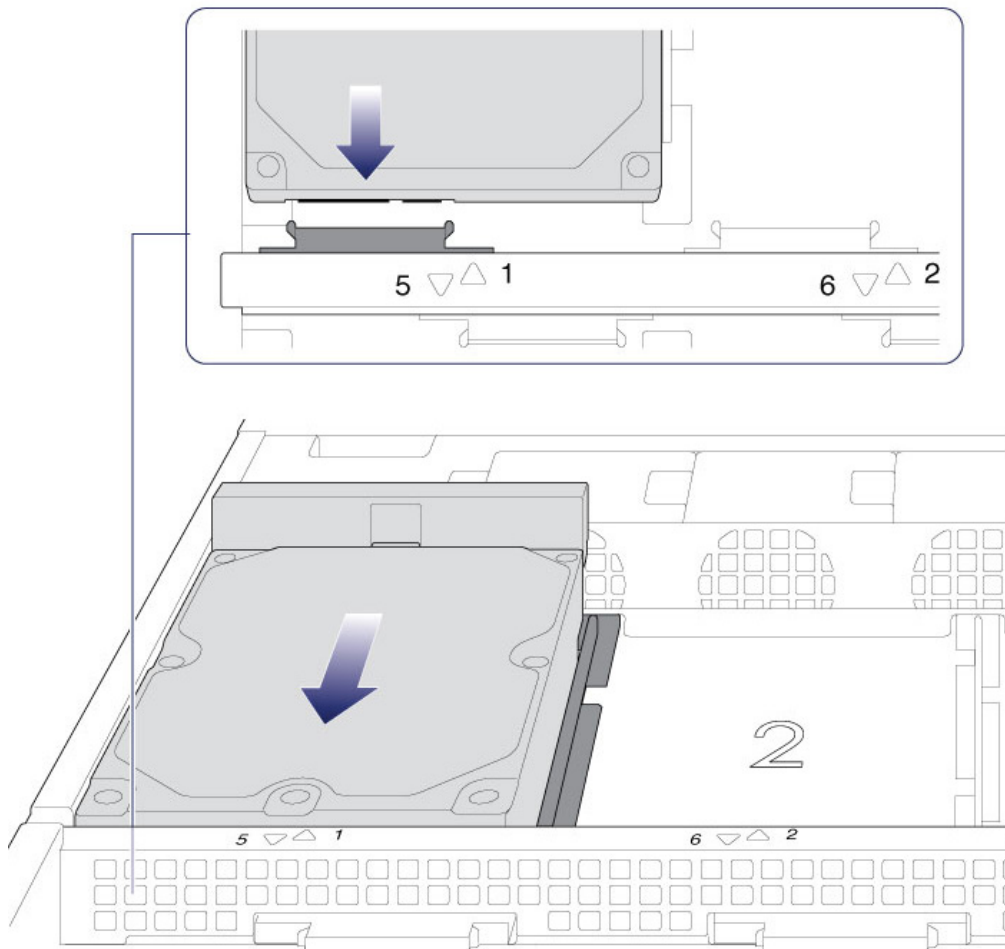

4. Close the hard drive's latch.

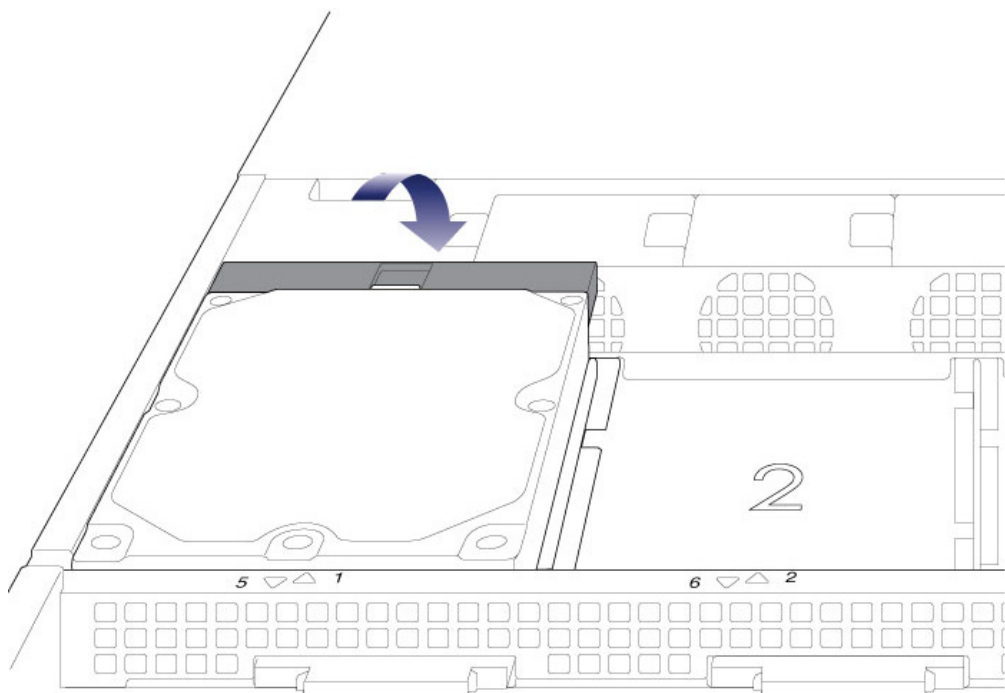

5. Repeat the steps for each hard drive.
6. Close the cover and slide the LaCie 8big into the rack. To unlock the rails, pull the rail fasteners on each side toward you. Secure the LaCie 8big to the rack using the two front screws.

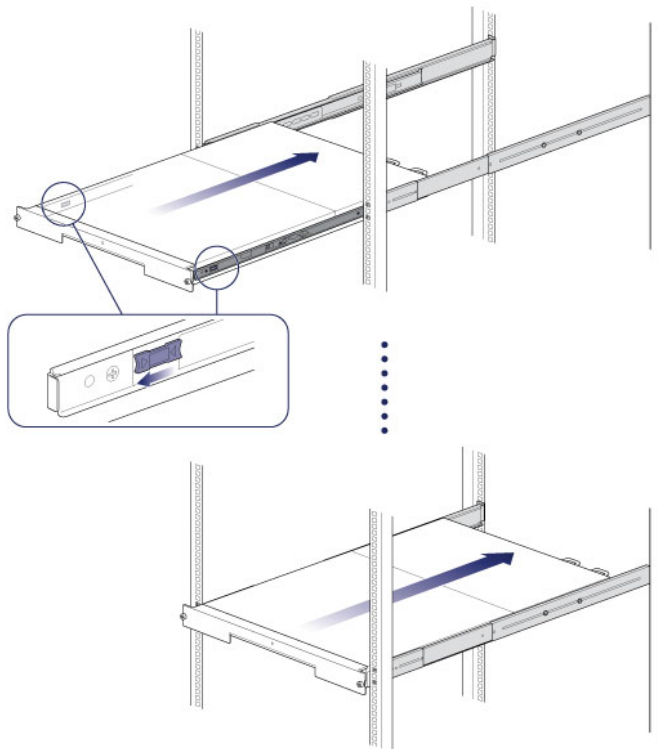

STEP 6 - PC AND POWER CONNECTIONS

1. Connect the power cables to active outlets.
2. Connect the Thunderbolt cable to your PC.

STEP 7 - START THE HARD DRIVES

1. Apply a short push to the power button. See [Operation](#) for details on how to use the power button.

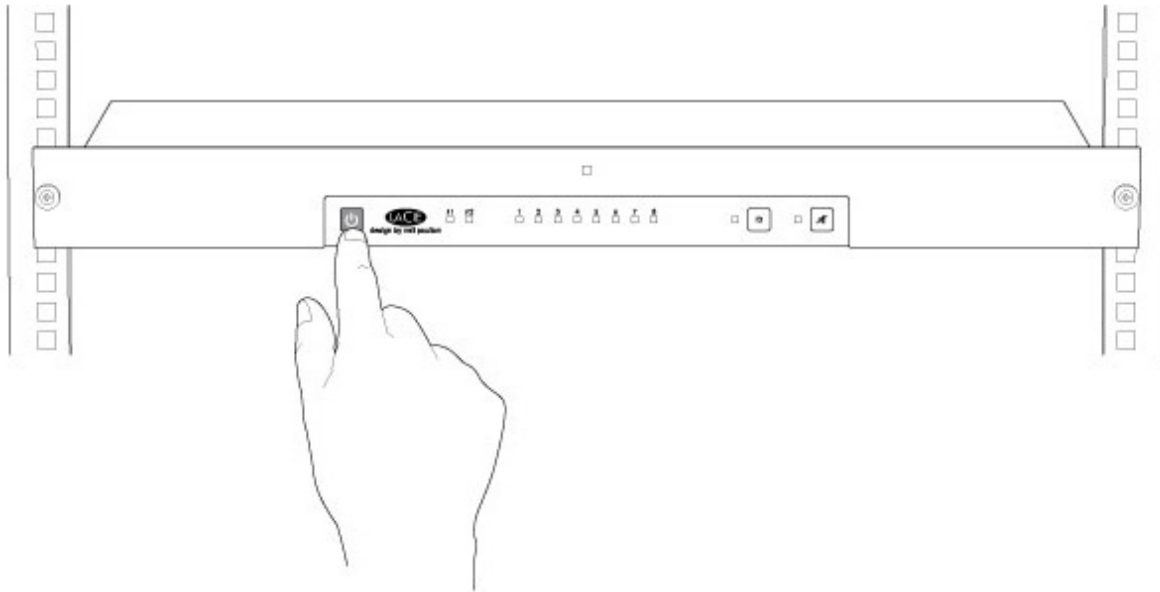

STEP 8 - DOWNLOAD THE THUNDERBOLT WINDOWS DRIVER

Perform the steps below on the PC that will use the 8big Rack Thunderbolt 2.

1. Download the driver at the following link: [Thunderbolt for Windows](#).
2. Unzip the downloaded file and note where it is located. For example, you can unzip the file on your PC's desktop.

STEP 9 - INSTALL THE THUNDERBOLT WINDOWS DRIVER

1. Go to **Start > Control Panel > Device Manager**.
2. Note that an item named *RAID Controller* appears in **Other devices**.

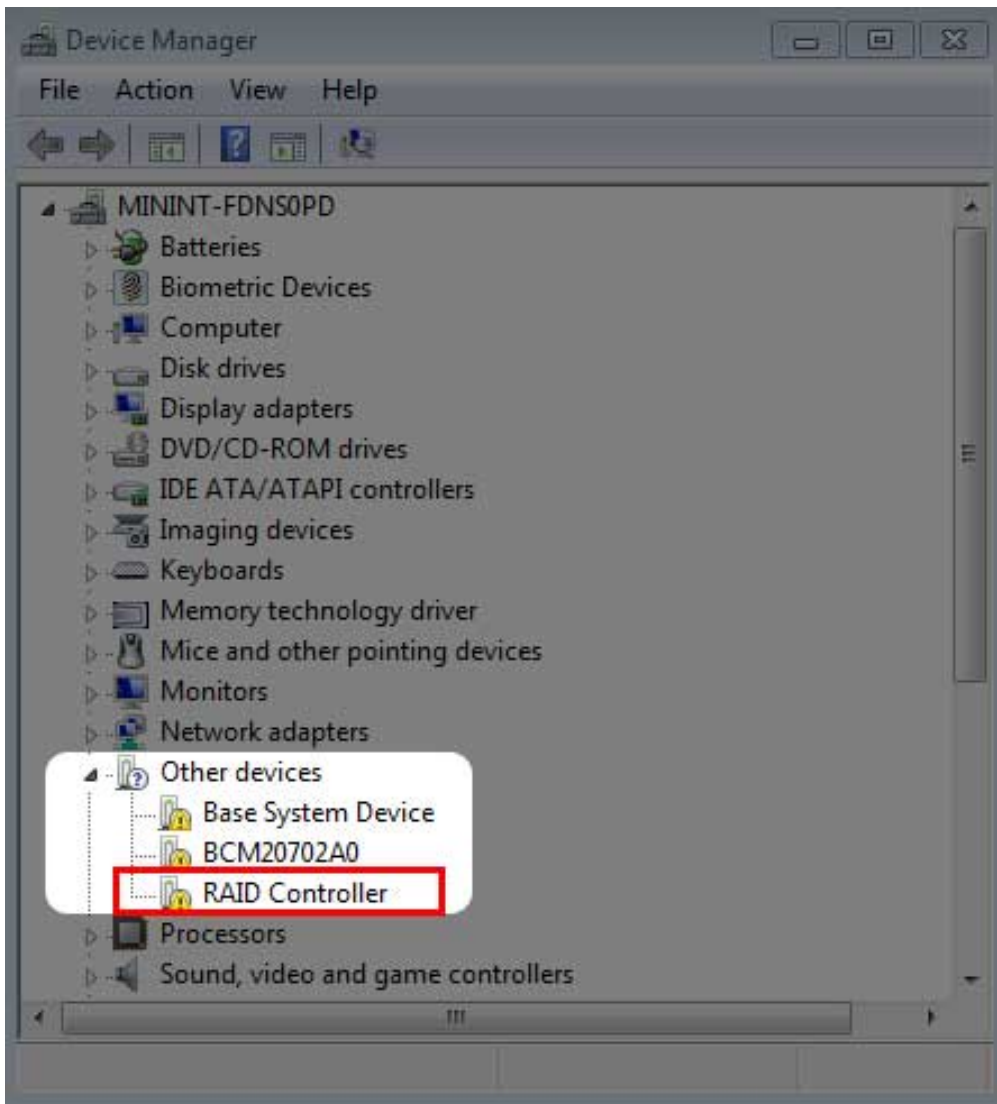

3. Right click **RAID Controller** and choose **Update Driver Software**.

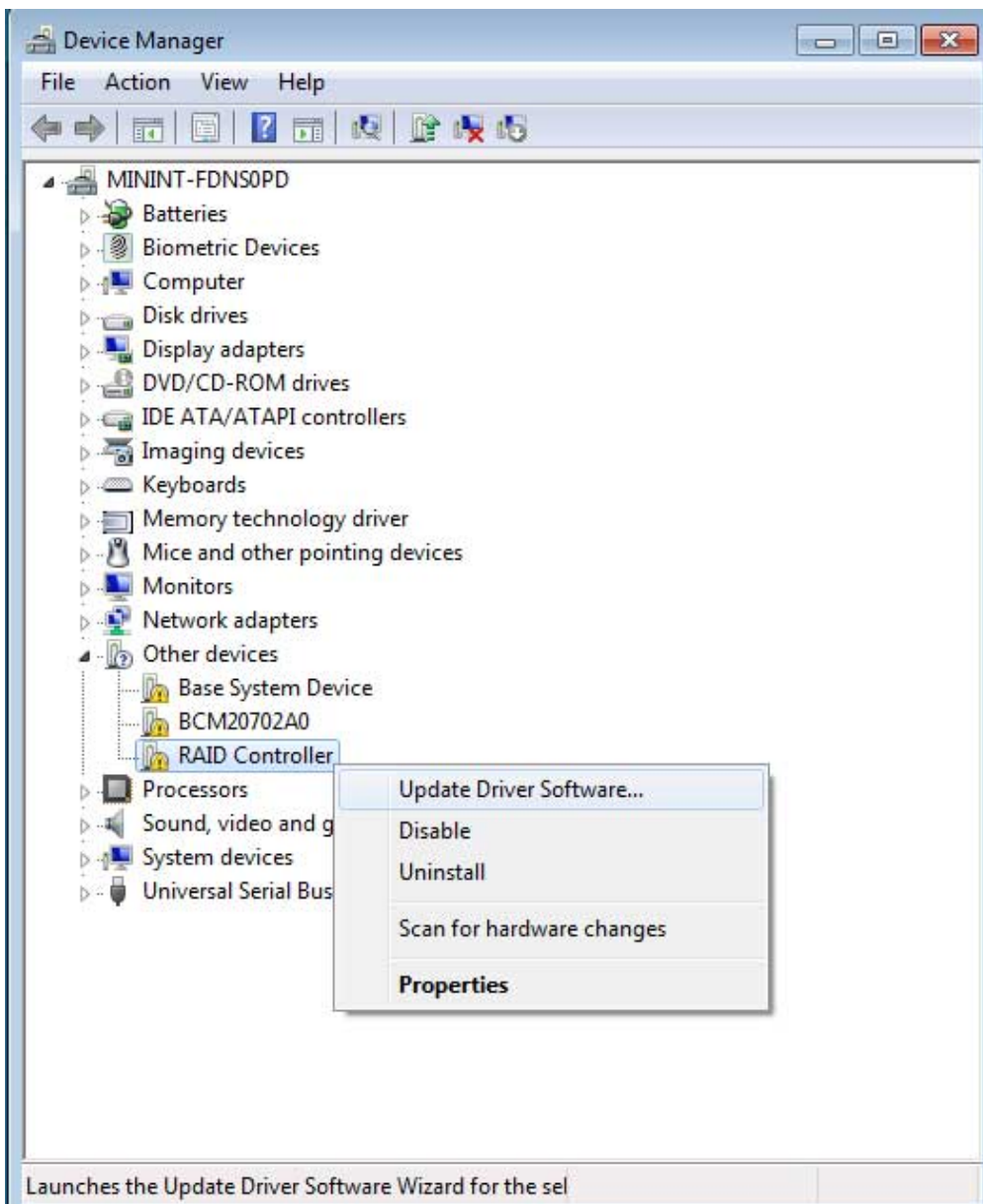

4. Choose **Browse my computer for driver software** and navigate to the driver downloaded in Step 7.

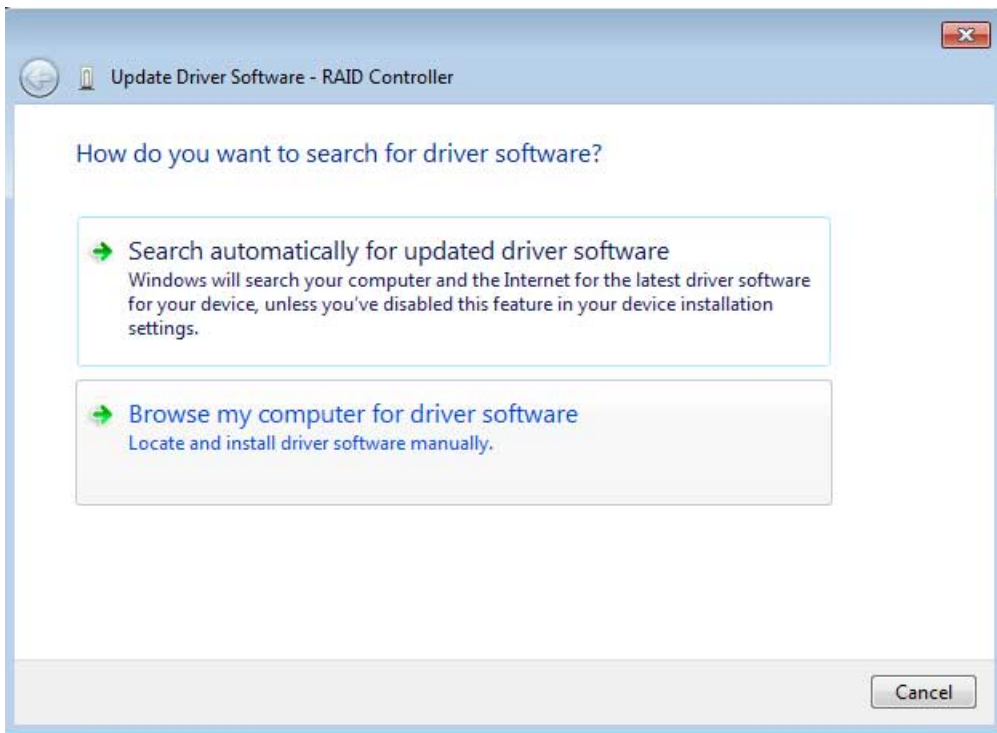

5. Choose the folder that applies to your version of Windows and then choose **OK**:

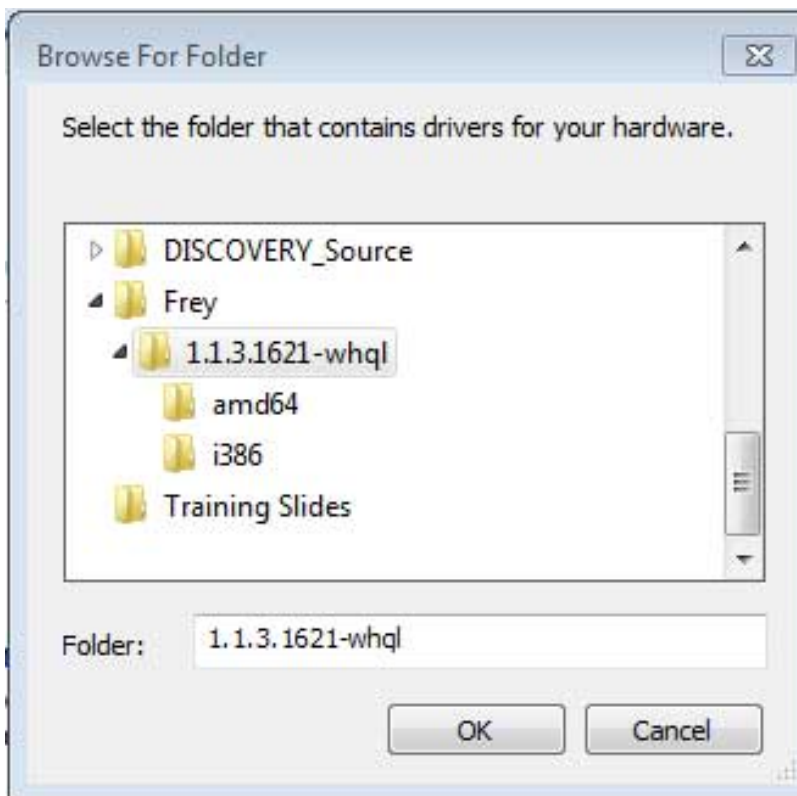

- 64-bit: Choose **amd64**.
 - 32-bit: Choose **i386**.
6. Choose **Next** to confirm the update.
7. Device Manager shows that the new driver has been installed.

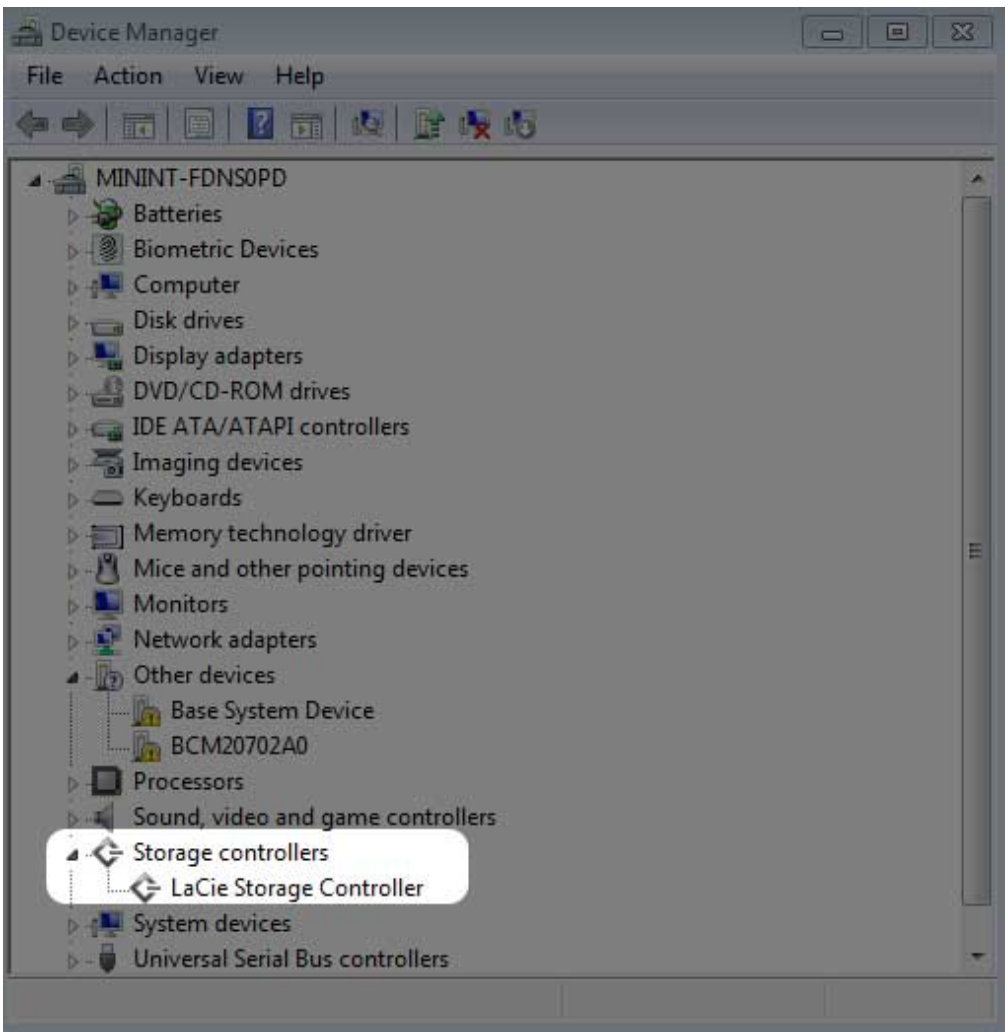

STEP 10 - CLEAN THE HARD DRIVES

Since the hard drives are formatted for Mac (HFS+), all partitions must be erased, including the EFI partition. Windows Disk Management cannot erase the EFI partition so you must run **Diskpart**, a separate Windows utility. For additional information on Diskpart, see the [web site](#).

Clean the hard drives

Important info: Diskpart deletes data from any hard drive that you select. Therefore, to avoid deleting data on other devices, disconnect all external hard drives from your PC except the LaCie 8big. Diskpart cannot delete the System disk.

Additionally, if your LaCie 8big has data, make certain to copy all files before performing the steps below. **LaCie is not responsible for lost data.**

1. Search for and launch **Diskpart**.

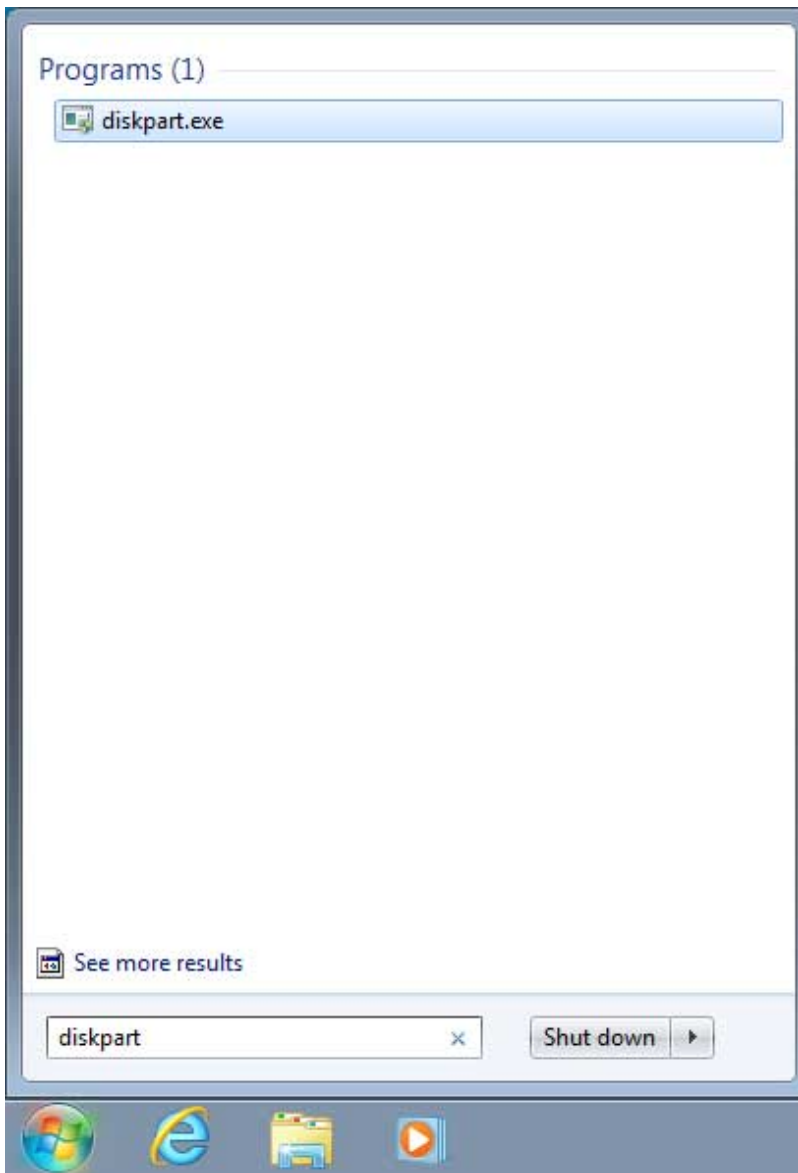

2. If you are prompted to authorize Diskpart, choose **Yes** or equivalent.
3. In the Diskpart prompt, type **list disk**.



```
C:\windows\system32\diskpart.exe
Microsoft DiskPart version 6.1.7601
Copyright (C) 1999-2008 Microsoft Corporation.
On computer: MININT-FDNS0PD
DISKPART> list disk_
```

4. Locate the disk number for your LaCie device then type **select disk *n***. *n* is the number for the LaCie hard drive enclosure (1 in the screenshot below). If you are uncertain of the disk number for the LaCie product, launch **Disk Management**. You should see the number assigned to the LaCie product.



```
C:\windows\system32\diskpart.exe
Microsoft DiskPart version 6.1.7601
Copyright (C) 1999-2008 Microsoft Corporation.
On computer: MININT-FDNS0PD
DISKPART> list disk

  Disk ###  Status         Size           Free           Dyn  Gpt
  -----  -
  Disk 0    Online         167 GB         0 B
  Disk 1    Online         13 TB         127 MB         *

DISKPART> select disk 1
```

5. Diskpart confirms that the disk has been selected.

```
C:\windows\system32\diskpart.exe
Microsoft DiskPart version 6.1.7601
Copyright (C) 1999-2008 Microsoft Corporation.
On computer: MININT-FDNS0PD

DISKPART> list disk

   Disk ###  Status         Size           Free           Dyn  Gpt
   -----  -
   Disk 0    Online         167 GB         0 B
   Disk 1    Online         13 TB         127 MB         *

DISKPART> select disk 1

Disk 1 is now the selected disk.

DISKPART>
```

6. To delete all partitions on the enclosure's hard drives, type **clean**.

```
C:\windows\system32\diskpart.exe
Microsoft DiskPart version 6.1.7601
Copyright (C) 1999-2008 Microsoft Corporation.
On computer: MININT-FDNS0PD

DISKPART> list disk

   Disk ###  Status         Size           Free           Dyn  Gpt
   -----  -
   Disk 0    Online         167 GB         0 B
   Disk 1    Online         13 TB         127 MB         *

DISKPART> select disk 1

Disk 1 is now the selected disk.

DISKPART> clean
```

Diskpart confirms that your hard drive is clean, meaning that the partitions have been deleted. The LaCie product is ready to be formatted for your operating system. See [Step 7 - Format the hard drives](#) for instructions.

STEP 11 - FORMAT THE HARD DRIVES

Formats

You can customize the storage device by reformatting it with separate file system formats. Review the formats below.

exFAT: exFAT is an update of FAT32, allowing for compatibility with Windows and Mac. While FAT32 is limited in regard to volume and file sizes, exFAT allows for volumes up to 128PB and files up to 16EB. Similar to FAT32,

exFAT is not optimized for performance with Windows devices.

NTFS: This acronym stands for New Technology File System, and it is the native file system for Windows 7 and Windows 8. NTFS offers several features that are not available with exFAT: file compression, encryption, permissions, auditing, and mirroring drives. The minimum supported volume size for NTFS is 10MB with a maximum of 2TB when initialized in the MBR format. For greater flexibility, use the GPT format with NTFS to remove limits on file and partition sizes. Volumes created in NTFS are native read and write for Windows 7 and Windows 8. Mac OS X 10.5 or higher can read and write to the NTFS partitions with the help of third-party drivers.

See the table below for a comparison of NTFS and exFAT.

Windows file system formats
Use NTFS if:
...you will be using the storage device only with Windows 7 and Windows 8. NTFS performance is significantly better than exFAT. This file system is also compatible in read-only mode with Mac OS 10.3 and higher.
Use exFAT if:
...you will be using your storage device with both Windows and Mac computers. Performance is not optimized for Thunderbolt/Thunderbolt 2.

Formatting Instructions

The steps listed below help you to format the storage device.

Caution: Formatting will erase everything on the storage device. **LaCie highly recommends that you back up all data on your storage device before performing the steps below. LaCie is not responsible for any data lost due to formatting, partitioning, or using a LaCie storage device.**

Note: Refer to your operating system's documentation for more information on formatting your storage device.

1. Make sure the storage device is connected to and mounted on the computer.
2. Right click on **Computer** and choose **Manage**. From the Manage window select **Disk Management**.
3. From the list of storage devices in the middle of the Disk Management window, locate your LaCie device.
4. Right click on the volume and select **New Simple Volume**. Follow the on-screen instructions when the New Simple Volume Wizard appears.

STEP 12 - DOWNLOAD AND INSTALL LACIE RAID MANAGER

LaCie RAID Manager is the software utility that manages the LaCie 8big's storage.

1. Download the installer at <http://www.lacie.com/support/raidmanager>.
2. Launch the installer on the computer that will connect to the LaCie 8big.
3. Follow the on-screen instructions to complete the installation.

For instructions, see the [LaCie RAID Manager user manual](#).

OPERATION

POWERING ON

The LaCie 8big Rack Thunderbolt 2 is available for use when:

- It is plugged into a live power outlet.
- It is connected to a computer that supports Thunderbolt 2 technology or first generation Thunderbolt technology.
- The ambient temperature is within the specified temperature range (see [System Overview](#)).

When booting the LaCie 8big, certain LEDs on the chassis will blink blue for a short period before turning solid blue. See [System LEDs](#) for further information.

To prepare the hard drives, follow the directions below:

1. Make sure that all the modules are firmly seated in their bays.
2. Confirm that the power supplies are connected to compatible powered outlets.
3. Apply a short push on the power button. See the explanations below to learn how to apply a short push and a long push.

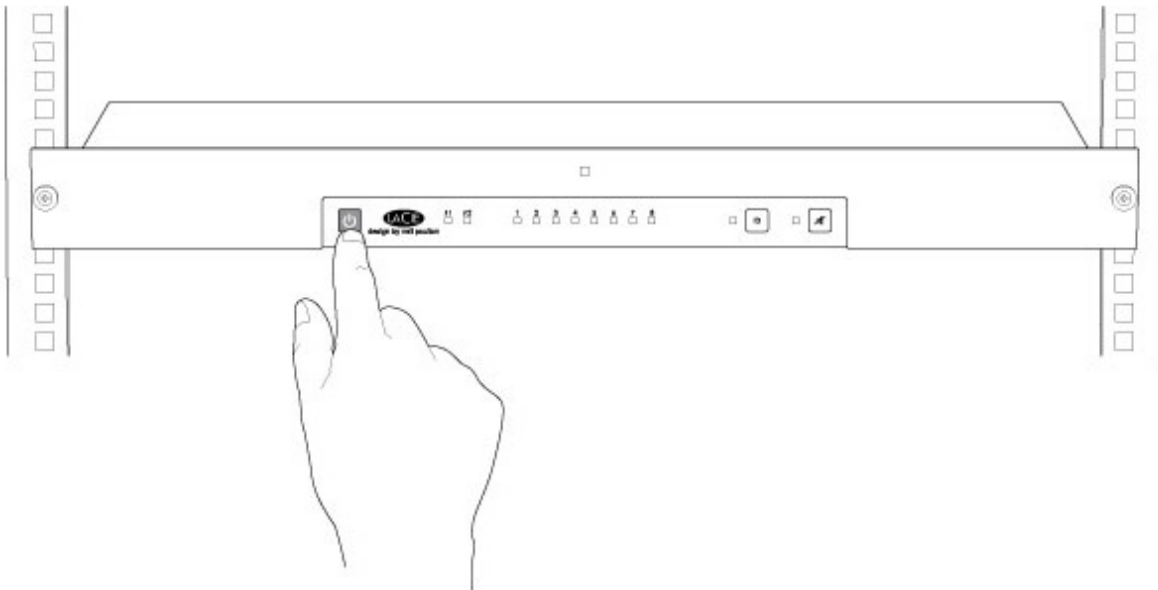

The hard drive LEDs blink blue while the hard drives spin up. You can start using the storage once the hard drive LEDs are solid blue.

POWERING OFF THE LACIE 8BIG HARD DRIVES: IDLE MODE

1. Make certain that the LaCie 8big is not in use and that there are no active transfers.
2. Eject the LaCie 8big volumes from your computer.
3. Apply a short push on the power button. See the explanations below to learn how to apply a short push and a long push.
4. The status LED blinks slowly while the hard drive LEDs turn off.

Thunderbolt 2 and first generation Thunderbolt devices daisy-chained to the enclosure receive power when the LaCie 8big is in idle mode.

POWERING OFF

1. Make certain that the LaCie 8big is not in use and that there are no active transfers.
2. Eject the LaCie 8big volumes from your computer.
3. Apply a short push on the power button. See the explanation below regarding a short push and a long push. The status LED blinks slowly while the hard drive LEDs turn off.
4. It is now safe to unplug the power cables from the device.

Important info: LaCie does not recommend applying a long push to power off the enclosure. See the explanation below for the long push.

Short push

Important info: Always eject the volume from your computer before applying a short push.

A short push is a manual depression on the power button that lasts no longer than one second. When the product is operating, a short push on the power button will spin down the hard drives within the enclosure. The Thunderbolt ports remain active and are available for daisy chaining. This is called idle mode. For example, a display that is daisy chained to the LaCie 8big will remain available to the computer following a short push.

Short push and RAID synchronization

Applying a short push during RAID synchronization spins the hard drives down. The RAID synchronization continues the next time you spin the hard drives up via a short push.

Long push

A long push is a manual depression on the power button that lasts more than four seconds. When the product is operating, a long push will cut the power from the LaCie 8big, forcing it to shut down immediately. A long push is not recommended as it may result in data loss. Therefore, it should only be used when troubleshooting a problem.

Removing the Thunderbolt cable during operation

It is highly recommended that users maintain the Thunderbolt cable connection between the computer and the LaCie 8big during operation. Removing the cable during operation can have serious consequences, such as lost data.

Disconnecting the Thunderbolt cable during RAID synchronization cuts communication between the computer and the storage. While the synchronization will continue, there is a strong risk of losing data.

DAISY CHAIN

Use the enclosure's two Thunderbolt 2 technology ports for:

- Direct connection to a computer that is compatible with Thunderbolt 2 technology or first generation Thunderbolt technology
- Daisy chaining with devices and displays that are compatible with Thunderbolt 2 technology and first generation Thunderbolt technology

DAISY CHAIN: THUNDERBOLT 2 TECHNOLOGY AND FIRST GENERATION THUNDERBOLT TECHNOLOGY

Thunderbolt 2 technology is an update of first generation Thunderbolt technology. While Thunderbolt technology continues to provide impressive transfer rates of up to 10Gb/s bi-directional, Thunderbolt 2 technology offers improved performance with a potential of up to 20Gb/s bi-directional. Thunderbolt 2 technology also gives you greater flexibility when using video and data, assigning greater throughput to the stream that carries the heavier load. You must have a computer that supports Thunderbolt 2 technology in order to take advantage of the updates in performance and the intelligent sharing of bandwidth.

Similar to first generation Thunderbolt technology, a single Thunderbolt 2 technology daisy chain can have up to seven devices, including the computer. For example, you can daisy chain five LaCie 8big Rack Thunderbolt 2 enclosures on the same line with a display. Provided that your computer supports Thunderbolt 2 technology, transfer rates have the potential to reach up to 20Gb/s bi-directional for all devices.

You can also add the LaCie 8big to a daisy chain that includes first generation Thunderbolt technology devices. For example, your computer supports Thunderbolt 2 technology and you add the LaCie 8big to a daisy chain that includes three first generation Thunderbolt technology storage devices and a display with a MiniDisplay port. In such a case, make certain that the LaCie 8big is the first enclosure connected to the computer. You can lose the higher performance offered by Thunderbolt 2 technology if a Thunderbolt 2 device is daisy-chained behind first generation Thunderbolt devices and/or displays.

How to daisy chain

Connect the cable to one of the interface ports on the back of the LaCie 8big and to your computer. The additional port may be used to daisy chain compatible first generation Thunderbolt and Thunderbolt 2 peripherals, such as hard drives and monitors. If you have another Thunderbolt 2 storage device, make certain to connect it to the LaCie 8big before adding first generation Thunderbolt technology devices and/or displays.

Important cable info: When connecting your enclosure to a computer or compatible devices, use cables specifically constructed to support Thunderbolt technology. Thunderbolt technology cables are compatible with Thunderbolt 2 technology devices and first generation Thunderbolt technology devices.

Important info: To reach Thunderbolt 2 technology transfer rates of up to 20Gb/s bi-directional, the LaCie 8big must be connected to a computer that supports Thunderbolt 2 technology. Connecting the LaCie 8big to a computer that supports first generation Thunderbolt technology allows for transfer rates up to 10Gb/s bi-directional.

Daisy chain: idle mode

You can daisy chain Thunderbolt 2 technology and first generation Thunderbolt technology devices even when the hard drives within the LaCie 8big are spun down. To spin down the hard drives, apply a short push on the power button (see [Operation](#)). The status LED blinks slowly, indicating that the LaCie 8big is in idle mode.

SOFTWARE

The storage for the LaCie 8big Rack Thunderbolt 2 is managed by LaCie RAID Manager. Use LaCie RAID Manager to:

- Identify the installed hard drives
- Configure RAID
- Check the health of the storage
- Set up storage alerts
- Troubleshoot the hard drives

See the [LaCie RAID Manager User Manual](#) for instructions on how to configure the LaCie 8big storage.

RAID

The information below provides a basic guide to the RAID modes available to the LaCie 8big Rack Thunderbolt 2. Note that the levels of performance and protection differ based upon the number of drives in a volume. For instructions on how to configure RAID, see the [LaCie RAID Manager User Manual](#).

RAID EXAMPLE

The level of RAID available to a volume is contingent upon the amount of hard drives. For example, a volume with four hard drives supports all levels of RAID except for RAID 1, which is not compatible with volumes greater than two hard drives. RAID 0 appears to be the best choice for a volume with four hard drives since it offers 100% storage capacity and the best performance. However, RAID 0 does not provide data protection in case of drive failure. Further, its performance is not much greater than RAID 5, which includes data protection in case one drive should fail.

RAID 6 and, in unique cases, RAID 10, can provide data protection in the event that two drives fail.

RAID LEVELS

Review the summaries of each RAID before selecting the configuration for the LaCie 8big storage.

RAID mode	Minimum hard drives
RAID 0	2
RAID 1	2
RAID 5	3
RAID 6	4
RAID 10	4

RAID 0

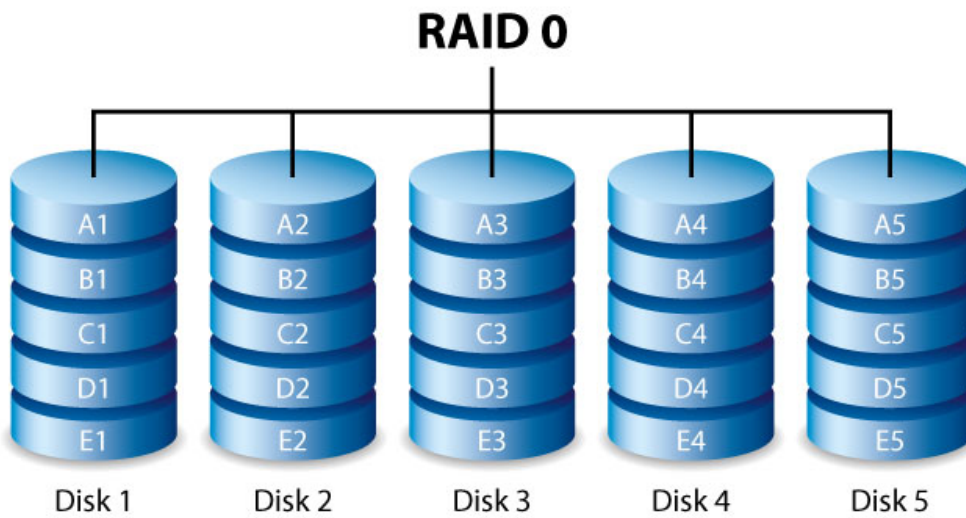

RAID 0 is the fastest RAID mode since it writes data across all of the volume's hard drives. Further, the capacities of each hard drive are added together for optimal data storage. However, RAID 0 lacks a very important feature: data protection. If one hard drive fails, all data becomes inaccessible. A recommended option is RAID 5, which offers comparable performance and data protection in case a single drive fails.

RAID 1

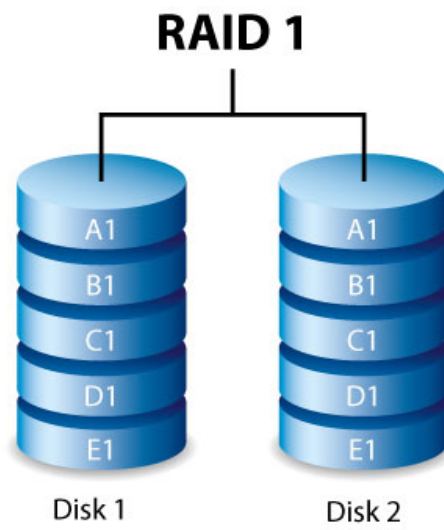

RAID 1 provides enhanced data security since all data is written to each hard drive in the volume. If a single hard drive fails, data remains available on the other hard drive in the volume. However, due to the time it takes to write data multiple times, performance is reduced. Additionally, RAID 1 will cut hard drive capacity by 50% or more since each bit of data is stored on all the hard drives in the volume.

RAID 5

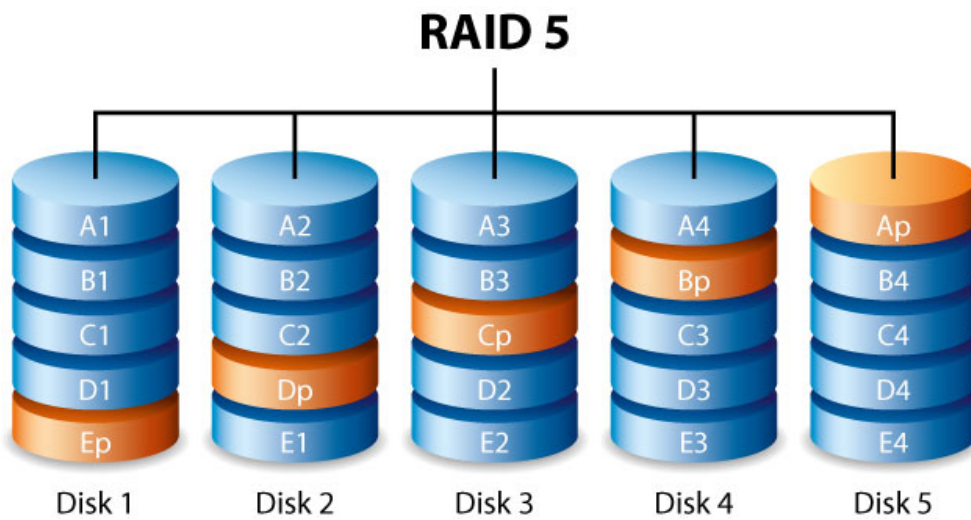

RAID 5 writes data across all hard drives in the volume and a parity block for each data block. If one physical hard drive fails, the data from the failed hard drive can be rebuilt onto a replacement hard drive. While the files stored on a RAID 5 volume remain intact should one hard drive fail, data can be lost if a second hard drive fails before the RAID is rebuilt with the replacement hard drive.

A minimum of three hard drives is required to create a RAID 5 volume.

RAID 5 offers comparable performance to RAID 0 with the advantage of protecting data. Additionally, you still have 75% of the storage capacity of a RAID 0 array (based upon total available hard drives and storage capacities).

RAID 6

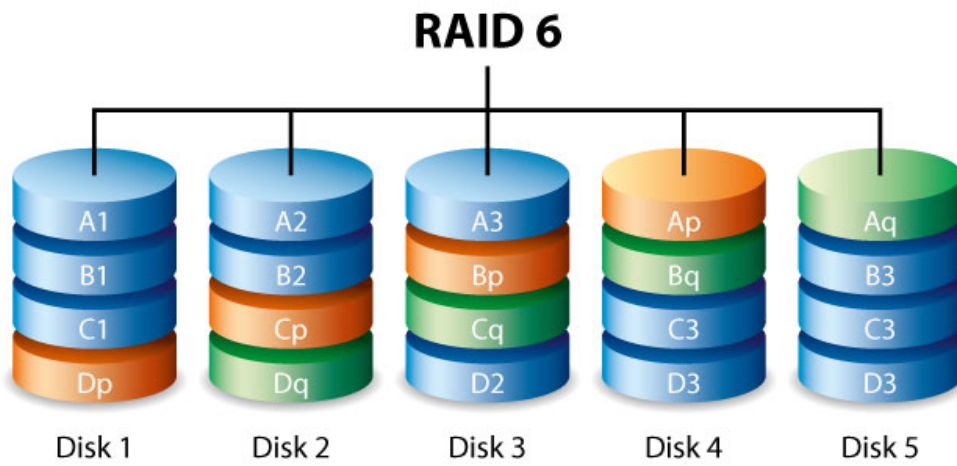

RAID 6 writes data across all hard drives in the volume and two parity blocks for each data block. If one physical hard drive fails, the data from the failed hard drive can be rebuilt onto a replacement hard drive. With two parity blocks per data block, RAID 6 supports up to two hard drive failures with no data loss.

RAID 6 synchronizing from a failed hard drive is slower than RAID 5 due to the use of double parity. However, it is far less critical due to its double-disk security.

A minimum of four hard drives is required to create a RAID 6 volume. RAID 6 offers very good data protection with a slight loss in performance compared to RAID 5.

RAID 10

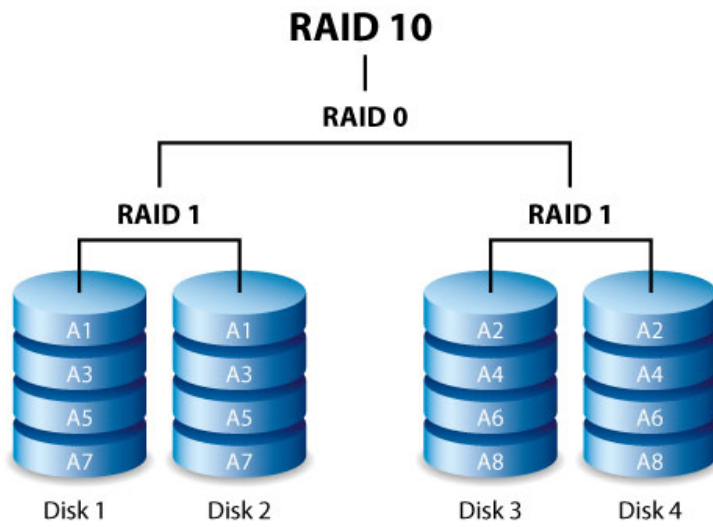

RAID 10 combines the protection of RAID 1 with the performance of RAID 0. Using four hard drive as an example, RAID 10 creates two RAID 1 segments, and then combines them into a RAID 0 stripe. With eight hard drive, the RAID 0 stripe will include four RAID 1 segments. Such configurations offer exceptional data protection, allowing for two hard drive to fail across two RAID 1 segments. Additionally, RAID 10 writes data at the file level and, due to the RAID 0 stripe, gives users higher performance when managing greater amounts of smaller files. This means a more generous input output per second for data, referred to as IOPS.

RAID 10 is a great choice for database managers that need to read and write a multitude of smaller files across the volume's hard drives. The impressive IOPS and data protection offered by RAID 10 gives database managers impressive reliability both in keeping files safe and rapid access.

RAID+Spare

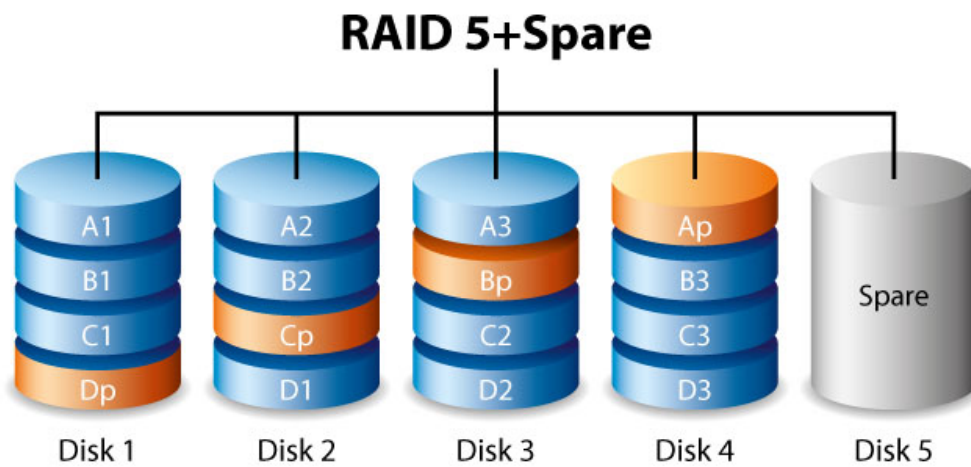

A RAID+Spare volume gives you a “hot-spare” that is ready to synchronize data immediately should a hard drive fail. If a hard drive in the volume fails, the data starts to synchronize with the spare. The clear advantage for a RAID volume with a spare is that you do not have to wait for a replacement hard drive. However, the spare cannot be used as storage during standard operation since its sole task is to take over should a hard drive fail. You can replace the failed hard drive once synchronization is complete and use it as the new hot spare.

Important info: For RAID+Spare volumes, data remains intact when a single hard drive fails and the spare begins synchronizing automatically. However, if a second hard drive in a RAID 5 volume fails before synchronization is complete, all data in the volume will be lost. The same is true for a RAID 1 volume. In the case of RAID 10, the second failed hard drive would have to be on the same mirrored set as the spare hard drive that is synchronizing data for the RAID to break. RAID 6 allows for two hard drives to fail.

HARDWARE MAINTENANCE

The LaCie 8big Rack Thunderbolt 2 has a front chassis and rear chassis, each with its own cover. Review the details below for hardware module locations and, where applicable, replacement.

Important info: Refer to the product's [Warranty Information](#) before performing any hardware repairs or maintenance that is not described in this manual.

PRECAUTIONS

- “Hot-swapping” means that you can perform maintenance or upgrade hardware while the LaCie 8big Rack Thunderbolt 2 is powered on. The LaCie 8big features three hot-swappable parts: hard drives; fans; and power supply units.
- During operation, all provided hardware (including the installed hard drives in their frames) should remain in place for optimal air flow. Users with less than eight hard drives are not required to install empty hard drive trays in the enclosure. Airflow and fan performance are regulated by temperature.
- Observe all conventional ESD precautions when handling the LaCie 8big parts.
- Apart from hot-swapping operations, the front top cover should be removed only when the unit has been turned off and allowed to cool down. Potential hazards of opening the cover while the product is powered on includes, but is not limited to, hot surfaces and exposed parts.
- The rear of the LaCie 8big features parts integral to operation. However, none of the parts are hot-swappable or serviceable by users. Removing the rear cover without the express permission of LaCie technical support will void the warranty for the LaCie 8big Rack Thunderbolt 2.

Important info: Your LaCie professional DAS gives you instant updates on the health of the enclosure and its hard drives. In addition to LED status indications, you can configure the system to send you email alerts (see the user manual for [LaCie RAID Manager](#)). Further, the enclosure will sound an alarm should a serious error occur (see [System Overview](#)). It is highly recommended that you address all warnings and alerts immediately. Ignoring a potential problem or urgent hardware alert can lead to irreparable damage to the DAS and a serious loss of data.

REPLACING A POWER SUPPLY UNIT (PSU)

For optimal power management, the power load for the LaCie 8big can be shared between the two PSU. If one should fail, all power will automatically run from the active PSU, guaranteeing continuous operation. To help extend the lifetime of your hardware, make certain to replace a failed PSU as soon as possible.

Follow the instructions below to replace a PSU:

1. Locate the PSU on the rear of the enclosure.
2. Unlock the PSU by pushing its latch toward the handle.

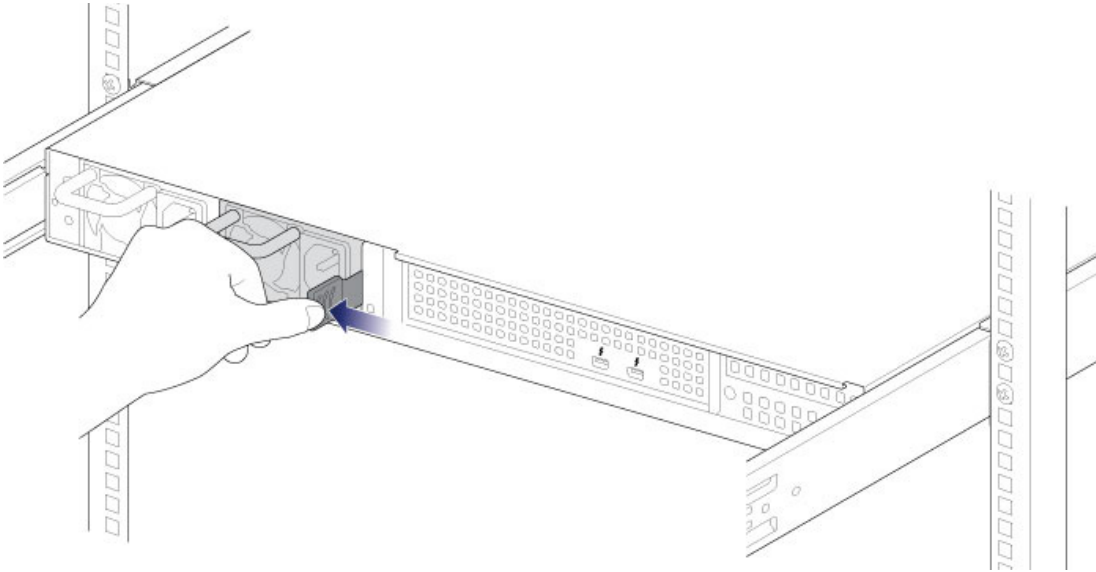

3. Remove the PSU by pulling the handle away from the LaCie 8big.

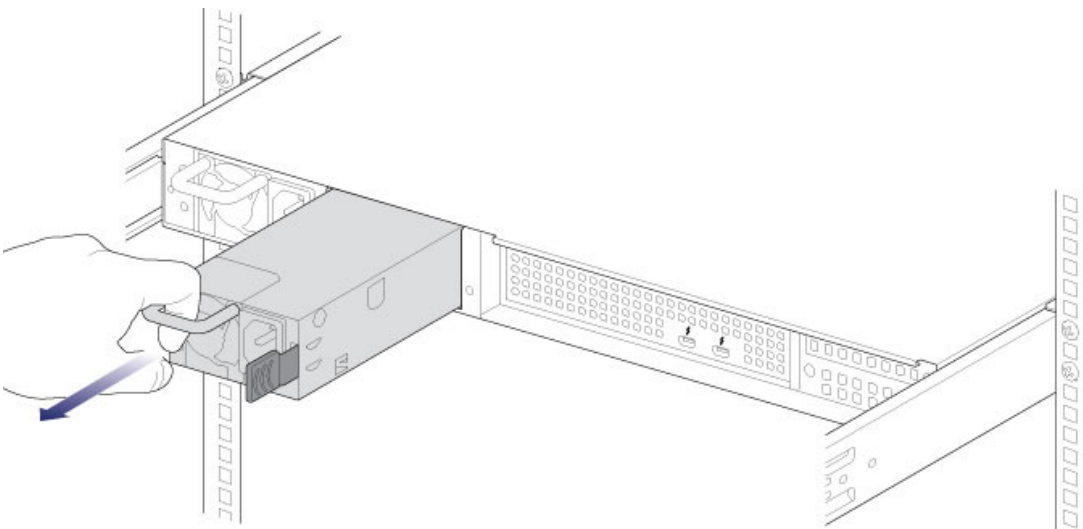

4. Insert the replacement PSU into the empty PSU slot.

Note regarding power supplies: Certain LaCie 8big models are shipped with one power supply.

FRONT CHASSIS

Removing the front cover

Make certain that the LaCie 8big is not being accessed before following the steps below.

1. (Skip this step if you are hot-swapping hard drives or fans.) Eject the LaCie 8big volumes from the computer and apply a short push on the power button. Wait for the components to completely cool before moving to Step 2.
2. Slide the enclosure toward you until it locks into position.

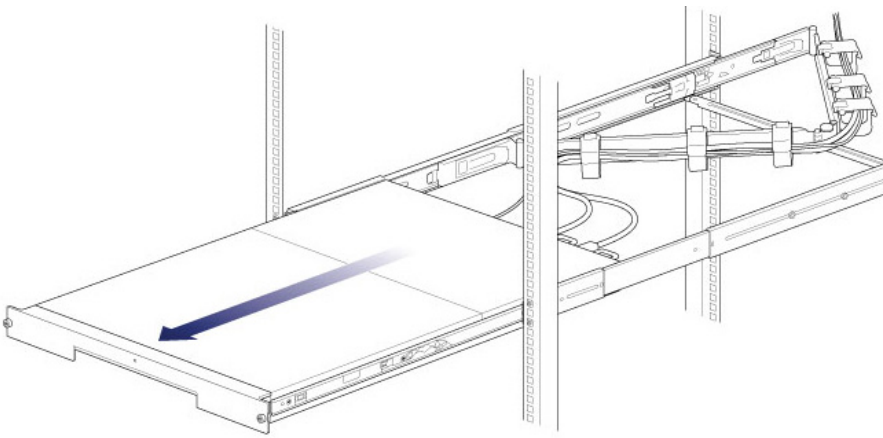

3. Release the cover by simultaneously pushing both front latches toward you.

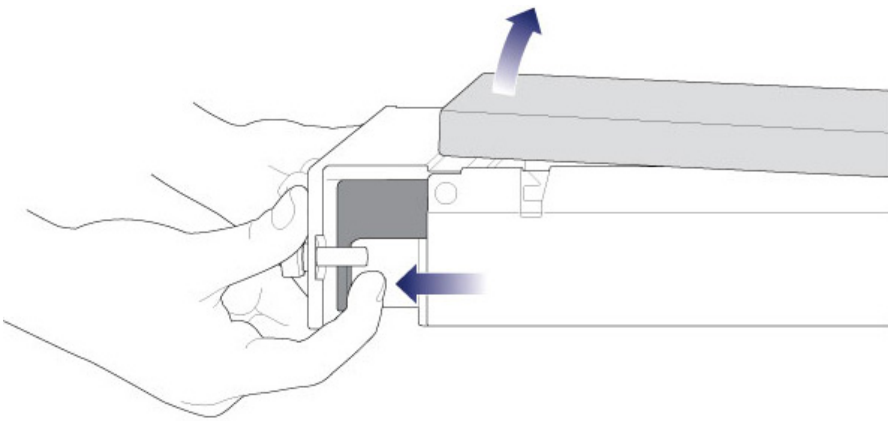

4. Lift the cover and remove it from the enclosure.

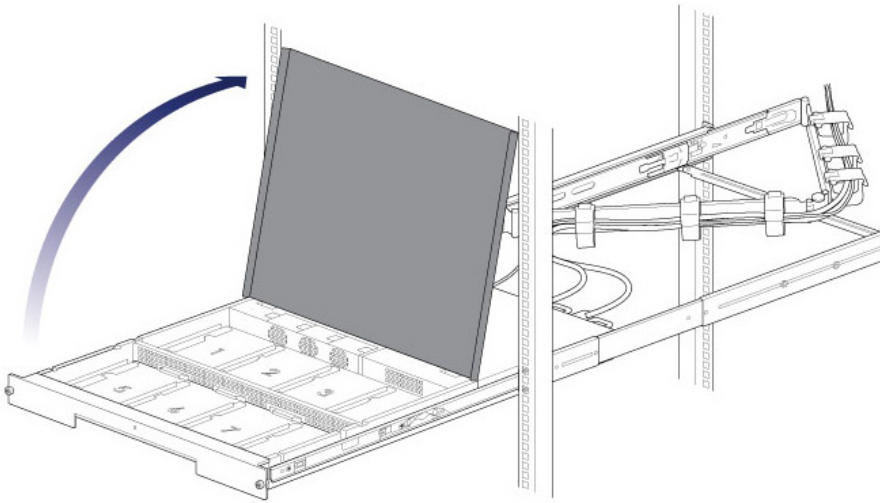

Front chassis components



1. Fans (x3)
2. Frame 1, hard drives 1 - 4
3. Hard drive LEDs; SATA connections
4. Frame 2, hard drives 5 - 8

REPLACING A HARD DRIVE

If a failed hard drive is under warranty, make certain to contact LaCie Technical Support to receive a replacement hard drive (see [Getting Help](#) for contact information). When adding or replacing hard drives, consider using Seagate Desktop HDD that are optimized for use with your LaCie 8big. For further information on compatible hard drives, visit [LaCie Technical Support](#).

Important info:

Replace a faulty hard drive with a hard drive of equal or greater capacity.

For a list of compatible hard drives, visit [LaCie 8big Rack Thunderbolt 2 hard drives](#).

When handling hard drives, make sure that they are placed and stored on a cushioned surface.

Important info: When following the instructions below, make certain to place the new or replacement hard drive on the hard drive guides before connecting the ends to the SATA connection. Attaching the hard drive to the SATA connection before placing it on the guides will damage the SATA connection.

1. Remove the cover as described above.
2. Locate the hard drive that you want to replace and push its lock button to open the latch.

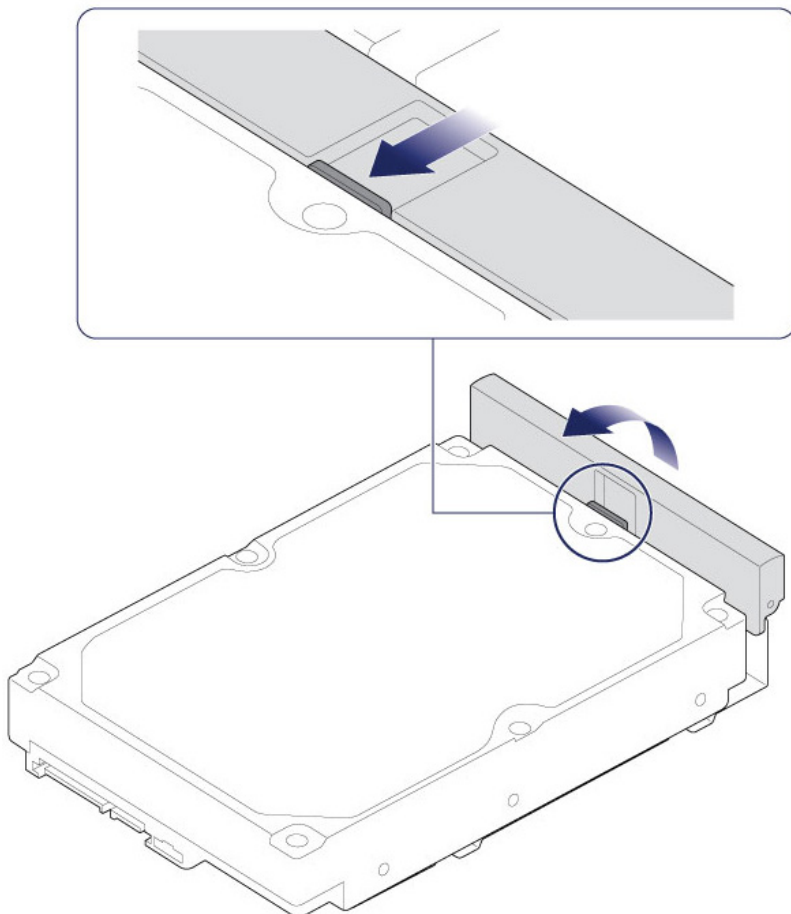

- Slide the hard drive away from its SATA connection and lift it from the slot.
- If applicable, remove the old hard drive from the tray and replace it with the new hard drive. Make certain to use the same four screws when fixing the new hard drive to the tray.
- Place the hard drive on the hard drive guides. Confirm that the hard drive is correctly aligned on the guides by gently pushing it away from the SATA connection.

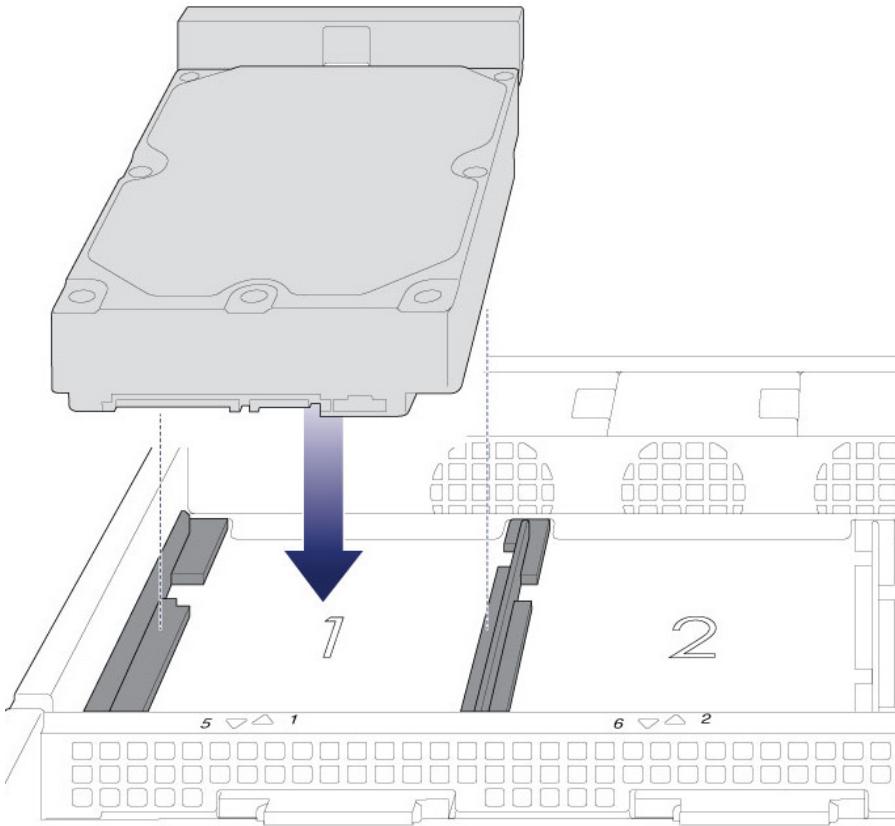

- Slide the hard drive into the SATA connection.

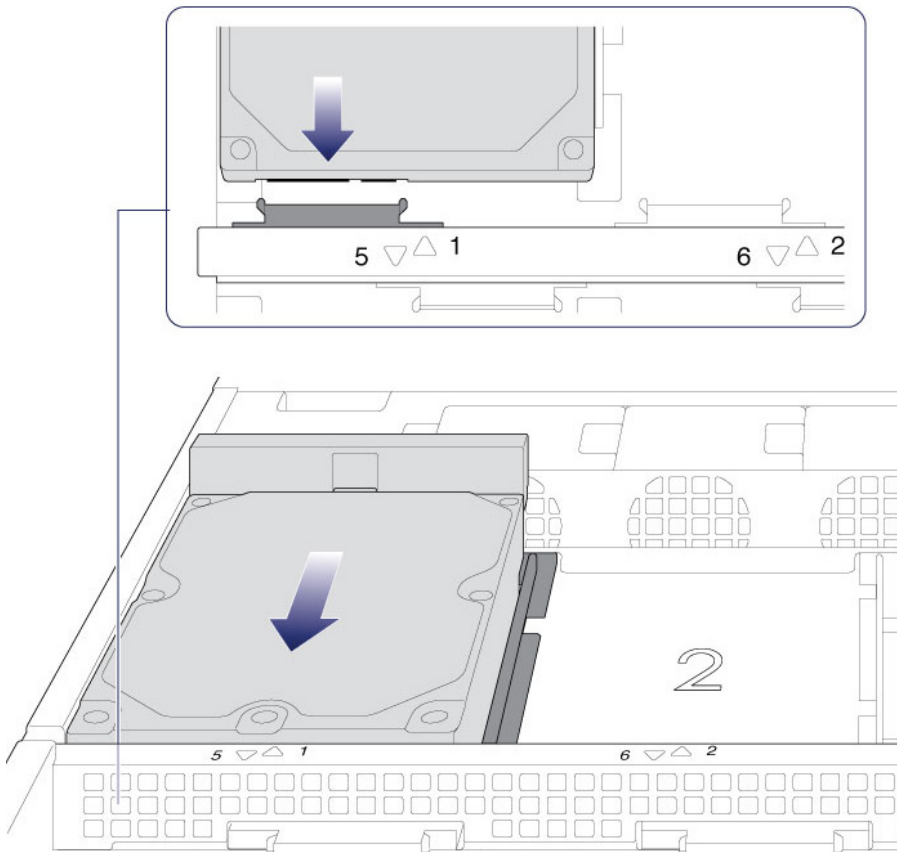

7. Close the hard drive's latch.

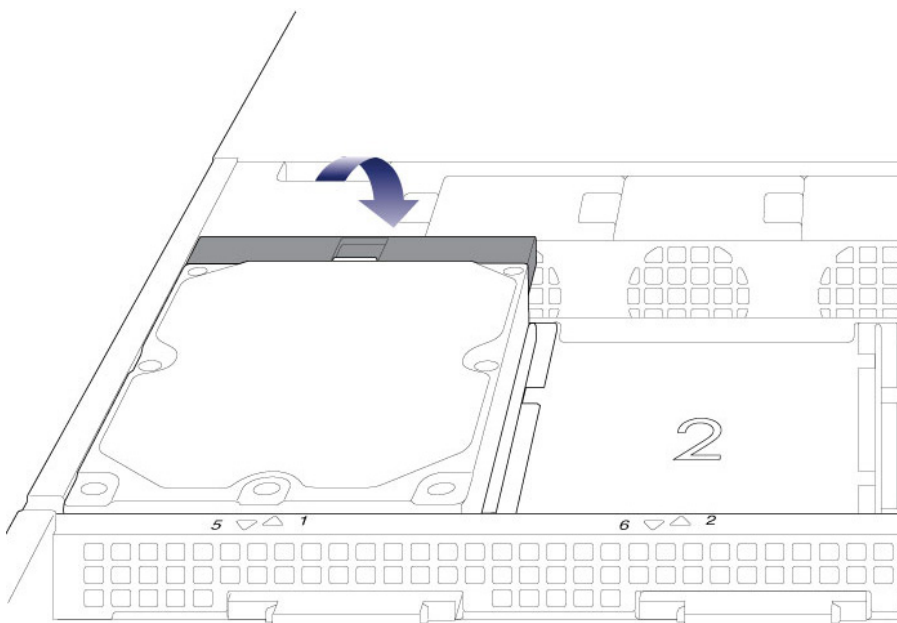

8. Repeat the steps for each hard drive.

9. Replace the cover and slide the enclosure into the rack. To unlock the rails, pull the rail fasteners on each side toward you. Secure the DAS to the rack using the two front screws.

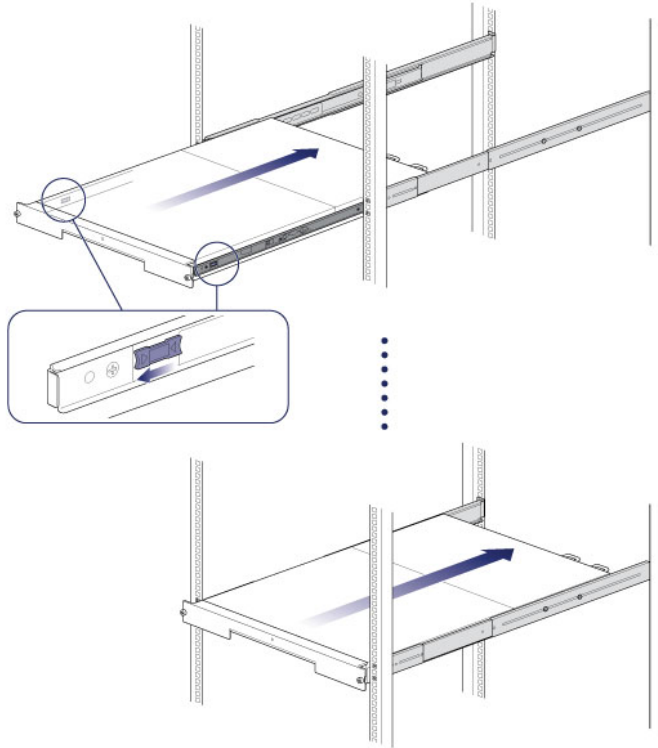

When replacing hard drives that are members of an active RAID configuration, the hard drive LEDs will blink red and blue indicating that the RAID is synchronizing data. You can continue to use the LaCie 8big storage but performance will be reduced until the synchronization is complete.

Replacing a fan

Caution: The fans are hot-swappable and can be replaced when the LaCie 8big is powered on. You must use caution when removing a fan. In most instances, the fan will stop rotating once it is removed from its slot. It is highly recommended that you use extreme caution with the fans since **moving parts can cause severe damage to your hands and body.**

Important info: The LaCie 8big is temperature controlled via an internal sensor. When removing one of the three fans, the other two will turn faster to maintain the required operational temperature. The faster rotation will be sudden and can become loud. If your fans appear to be louder than normal, confirm that the room's temperature is within operational range (see [Safety Guidelines](#)).

1. Remove the cover as described above.
2. Using your forefinger and thumb, pinch the clips that secure the fan to its slot.

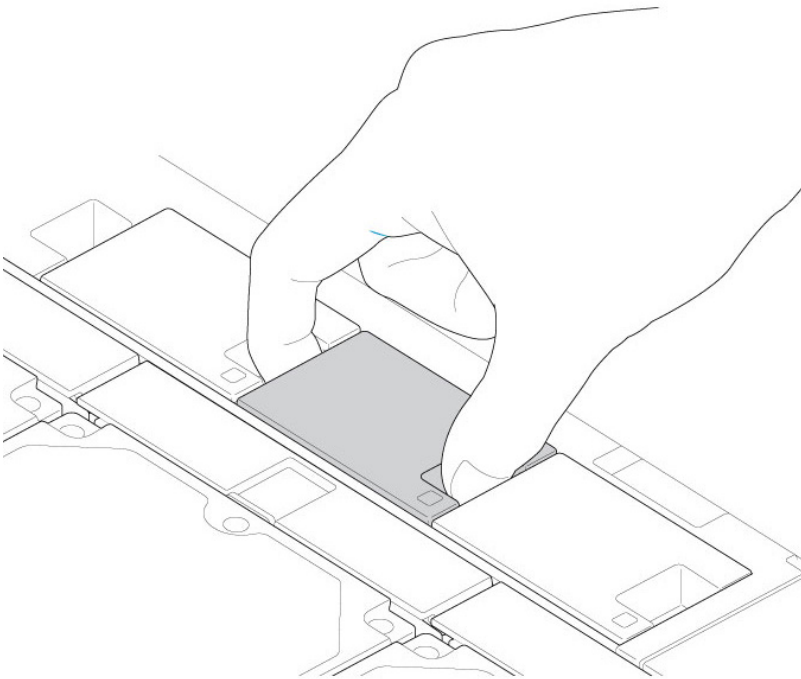

3. Lift the fan from its slot. **Show caution when removing the fan since moving parts can cause severe damage.** The fan should stop rotating once it is removed from its slot.

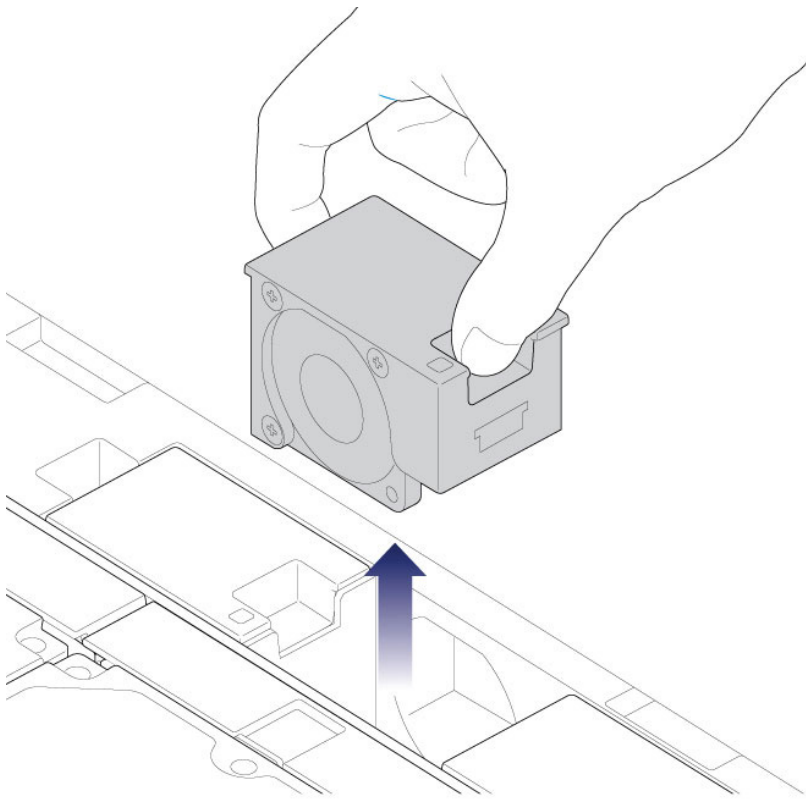

4. Insert the replacement fan into the empty slot.

REAR CHASSIS: NON-SERVICEABLE COMPONENTS

The components in the rear chassis are **NOT** hot-swappable and are **NOT** serviceable at any location outside of LaCie-approved service centers. **Removing the rear cover without permission from LaCie technical support will void your product's warranty.** Additionally, removing, replacing, or changing any part in the rear chassis or, performing any action that involves the components in the rear chassis, will void the product's warranty. If you are experiencing hardware errors or failure, contact LaCie technical support for assistance (see [Getting Help](#) for contact information).

Rear chassis components

1. Thunderbolt 2 controller (20Gb/s)
2. RAID controller (RAID on Chip)
3. DDR3 SDRAM

GETTING HELP

If you are having problems with your LaCie product, consult the table below for a list of available resources.

Order	Source	Description	Location
1	Quick Install Guide	Concise steps to follow for getting your product up and running	Either a printed leaflet or accessory box and included in the product box, or download PDF from the product page
2	Support Pages	Includes interactive troubleshooting topics for most common problems	www.lacie.com/support/ , select your product, then click the "Troubleshooting" tab
3	User Manual	Includes common troubleshooting topics	See Troubleshooting Topics below
4	Customer Support	Create an account on lacie.com , register your product, and fill out a support ticket	Create an account here: www.lacie.com/us/mystuff/login.htm?logout&rtn=mystuff

Note: LaCie is dedicated to providing high quality products that enrich the lives of our customers. To help LaCie offer the best customer support, we encourage you to create an account and register your product at www.lacie.com/us/mystuff/login.htm?logout&rtn=mystuff. You can give us important feedback as well as receive updated information on your LaCie device.

TROUBLESHOOTING TOPICS

Note: Interactive troubleshooting, a highly effective way to resolve problems with your product, is available from www.lacie.com/support/. Select your product, then click the “Troubleshooting” tab.

The LaCie 8big Rack Thunderbolt 2 will not turn on.

Q: Can you confirm that the LaCie 8big is properly connected?

A: Make certain:

- The power cables are properly connected to one or both power supplies and to a live power source.
- The Thunderbolt cable is connected to a computer that supports Thunderbolt 2 technology or first generation Thunderbolt technology.
- The computer connected to the LaCie 8big is powered on.
- The power button on the front of the LaCie 8big was pushed as noted in [Setting Up](#).

Q: Is there a problem with one or both power supply units?

A: Your LaCie 8big has redundant power supplies. Each power supply provides sufficient power to keep the LaCie 8big running in case the other one fails. Contact LaCie technical support if you believe that one or both power supplies have failed. In the rare case in which both power supplies fail at the same time, you may be asked to send the enclosure to LaCie for review.

The LaCie 8big turns off when I daisy chain a device.

Q: Did the product turn off as soon as the device and the LaCie 8big’s Thunderbolt 2 port came into contact?

A: The device may not be compatible with Thunderbolt products. Unplug any devices you have connected and reboot the product.

The LaCie 8big is unresponsive.

Q: Have you tried to restart the system?

A: Eject the volume from the computer and shut down the LaCie 8big by applying a short push on the front button. If nothing happens after a few minutes, you can force the LaCie 8big to turn off by applying a long push (more than four seconds), then release it. Once off, restart the product by pushing and immediately releasing the front button.

Note that a long push is not recommended under standard operating conditions as it may result in data loss. Once the status LED stops blinking blue, check your computer for proper connection to the LaCie 8big volumes.

The LaCie 8big is overheating.

Q: Is the ambient temperature too high? Is the air output blocked? Are several fans malfunctioning?

A: If the ambient temperature is below 40°C and the ventilation is cleared, you may have one or several malfunctioning fans. Contact LaCie technical support.

I am not certain if the LaCie 8big firmware should be updated.

Q: Where can I check the firmware version?

A: Check LaCie RAID Manager for the firmware version.

Q: How do I know if the firmware is the latest version?

A: Go to the [LaCie technical support](#) for the latest information on the product.

Problem: I do not see the LaCie 8big on my computer.

Q: Did you install LaCie RAID Manager?

A: The installer for LaCie RAID Manager includes a driver to recognize and mount the 8big storage.

Q: Are there first generation Thunderbolt technology and/or Thunderbolt 2 devices connected to the same port?

A: Disconnect other Thunderbolt devices and see if the LaCie 8big volume appears on the desktop.

Q: Does the icon/Do the icons for the LaCie 8big volume(s) appear on the desktop?

A: The hard drive icon(s) for the storage should appear on your desktop. Confirm that the Finder preference for displaying external hard drives on the desktop is selected at **Finder > Preferences > General**.

Q: Is the Thunderbolt 2 technology enclosure connected to a computer that supports Thunderbolt 2 technology or first generation Thunderbolt technology?

A: The connection type for Thunderbolt 2 technology and first generation Thunderbolt technology is the Mini DisplayPort. While older Macintosh computers include Mini DisplayPorts, they are only used to connect one or more monitors. Legacy Macs with Mini DisplayPorts do not support Thunderbolt 2 technology devices such as the LaCie 8big.

Q: Did you follow the correct installation steps?

A: Review the installation steps ([Setting Up](#)). Make certain that both ends of the Thunderbolt cable are firmly connected to the ports and that the device is receiving power via the included power supply.

Q: I connected the enclosure to my new Mac with an older Mini DisplayPort cable that I use for my monitors. Why can't I see the volume(s) on the desktop?

A: Thunderbolt 2 storage requires cables specifically constructed for Thunderbolt technology. Use the cable that was shipped with your device.

Q: I connected a cable that supports Thunderbolt technology to my new Mac but the LaCie 8big does: (a.) not power on and/or (b.) not receive sufficient power.

A: The enclosure must also receive power via the included power supply. See [Setting Up](#).

Q: Are both ends of the Thunderbolt technology cable securely attached?

A:

- Only use a cable that supports Thunderbolt technology.
- Check both ends of the Thunderbolt cable to make sure they are fully seated in their respective ports.
- Try disconnecting the Thunderbolt cable then wait 10 seconds before reconnecting it.
- If the hard drive is still not recognized, restart your computer and try again.

Problem: I'm receiving file transfer error messages and Time Machine does not work.

Q: Did you get an "Error -50" message while copying to the storage?

A: When copying files or folders from a computer to a FAT 32 volume, certain characters cannot be copied. These characters include, but are not limited to:

? < > / \ :

Since it does not offer optimal performance, LaCie does not recommend using the FAT 32 file system with Thunderbolt 2 technology storage.

Q: Did you get an error message telling you that the hard drive has been disconnected when coming out of sleep mode?

A: Ignore this message. The hard drive will remount to the desktop.

Problem: The hard drive space does not seem right.

Q: I just threw a lot of files into the Trash. Why don't I see more space to copy new files?

A: Hard drive space will be reclaimed once files are erased. To remove the files forever:

- Click the **Trash** icon in the Dock.
 - A Finder window will open. Click **Empty** in the upper right.
-

Problem: The bandwidth for the LaCie 8big is not as fast as I had expected. It has the same transfer rates as my first generation Thunderbolt technology storage device.

Q: Does your computer support Thunderbolt 2?

A: The LaCie 8big must be connected to a computer that supports Thunderbolt 2 technology to attain Thunderbolt 2 technology transfer rates.

Q: Did you daisy chain the LaCie 8big with first generation Thunderbolt technology devices?

A: Thunderbolt 2 technology devices can share the same daisy chain with first generation Thunderbolt technology devices. However, the LaCie 8big can only reach Thunderbolt 2 transfer rates if it is connected directly to the computer with the other devices daisy-chained behind it. If your computer supports Thunderbolt 2 technology, make certain that the LaCie 8big is the first device in the daisy chain.

Q: Did you daisy chain the LaCie 8big behind a display?

A: Thunderbolt 2 technology devices can share the same daisy chain as a display. However, the LaCie 8big can only reach Thunderbolt 2 transfer rates if it is connected directly to the computer with the other devices daisy-chained behind it. If your computer supports Thunderbolt 2 technology, make certain that the LaCie 8big is the first device in the daisy chain.

SAFETY GUIDELINES

Important info: Do-it-yourself repairs not covered in this manual will invalidate the warranty.

SAFE HANDLING

The LaCie 8big Rack Thunderbolt 2 must run with all of its parts and units in place. In order to comply with applicable safety, emission, and thermal requirements, no covers should be removed during normal operation. All parts must be installed according to the instructions (see [Setting Up](#)).

Permanently unplug the unit if you think that it has become damaged in any way.

The LaCie 8big Rack Thunderbolt 2 features three parts that are hot-swappable:

- Hard drives (up to eight)
- Fans (x3)
- Power supply units (hot-swappable when two power supplies are installed and running)

The DAS can remain powered on when replacing a hot-swappable part. For all other types of maintenance and physical troubleshooting, shut down and disconnect power from the DAS. Only qualified technical service personnel should be allowed to maintain the DAS.

Shut down and unplug the unit before moving it.

Caution: If this equipment is used in a manner not specified by LaCie, the protection provided by the equipment may be impaired.

SAFETY

Power supplies

The LaCie 8big Rack Thunderbolt 2 must be operated from a minimum of one power supply unit. The input voltage range for a single power supply is 100-240V, 50/60Hz, 250W.

Make sure that the socket outlets are located near the equipment and are easily accessible.

Before removal/replacement of a power supply, disconnect the power supply cable for complete isolation.

Hot swapping a power supply is not supported on units that feature a single power supply or units with only one functional power supply.

ENVIRONMENT

A safe electrical ground connection must be provided to the power cord. Check the grounding of the enclosure before applying power.

Provide a suitable power source with electrical overload protection to meet the requirements laid down in the technical specification.

Never expose your device to rain, or use it near water, or in damp or wet conditions. Never place objects containing liquids on the enclosure, as they may spill into its openings. Doing so increases the risk of electrical shock, short-circuiting, fire, or personal injury.

Always unplug the device from the electrical outlet if there is a risk of lightning or if it will be unused for an extended period of time. Otherwise, there is an increased risk of electrical shock, short-circuiting, or fire.

Hot surfaces (heat sinks) are exposed when the enclosure top cover is removed. Disconnect power and allow the enclosure to cool before working inside the system.

When pulled out from the rack, the enclosure must not be used as a shelf to support any other object.

Caution: Do not remove covers from the PSU: there is a danger of electric shock inside. If the PSU fails during the warranty period, return it to LaCie.

Fans

WARNING: Removing the enclosure cover when the DAS is powered on will reveal moving parts, specifically the rotating fan blades. **You must remain vigilant when opening the enclosure cover. Above all, show extreme caution with the fans and other moving parts within the LaCie 8big Rack Thunderbolt 2.**

RACK SYSTEM SAFETY PRECAUTIONS

The rack cabinet must be capable of supporting the total weight of the installed enclosure(s) and the design should incorporate stabilizing features suitable to prevent the cabinet from tipping or being pushed over during installation or in normal use.

When loading a rack cabinet with the units, fill from the bottom up and empty it from the top down.

Do not add any load onto the LaCie 8big Rack Thunderbolt 2 when it is mounted on its rack rails and installed on its slide. Doing so can bend the rails and prevent the slide from proper operation.

Caution: To avoid danger of the cabinet toppling over, under no circumstances should more than one enclosure be drawn out of the rack cabinet at any one time.

The rack cabinet design should take into consideration the maximum operating ambient temperature for the unit, which is 40°C. Should the environment remain above 40°C for an extended period of time, there is a strong risk that the enclosure will automatically spin down the hard drives and enter idle mode. This is a safety precaution to protect the hard drives.

The rack cabinet should have a safe electrical distribution system. It must provide overcurrent protection for the unit and must not be overloaded by the total number of units installed in the rack. When addressing these concerns, consider the electrical power consumption rating shown on the product.

The electrical distribution system must provide a reliable ground for each unit and for the cabinet.

The power supply unit has a ground leakage current of 3.5mA. The design of the electrical distribution system must take into consideration the total ground leakage current from all the power supplies in all the units.

When configured, the cabinet must meet the safety requirements of IEC 60950-1 2nd edition.

RACK INSTALLATION PREREQUISITES

The LaCie LaCie 8big Rack Thunderbolt 2 enclosure is designed for installation into an industry standard 19-inch rack cabinet subject to the following requirements:

- There must be a minimum depth of 850mm (33.5 inches) from rack posts to maximum extremity of enclosure (including rear cabling and cable management kit).
- The rack must be able to support enclosures weighing up to 20Kg (45 lb.).
- There must be a minimum gap of 25mm (1 inch) between the rack cover and front of the enclosure.
- There must be a minimum gap of 50mm (2 inches) between the rear of the enclosure and the rear of the rack in order to maintain the correct air flow around the enclosure.
- Use in a fully enclosed rack installation is not recommended.
- The rack design should take into consideration the maximum operating ambient temperature for the unit, which is 40°C. Should the environment remain above 40°C for an extended period of time, there is a strong risk that the enclosure will automatically spin down the hard drives and enter idle mode. This is a safety precaution to protect the hard drives.
- The system must be operated with low pressure rear exhaust installation. The back pressure created by rack doors and obstacles must not exceed 5 pascals (0.5mm water gauge).

The top cover on the rear of the enclosure provides access to the the motherboard. Do not remove the top cover on the rear of the enclosure unless you are performing maintenance recommended by LaCie technical support. The unit must be turned off and allowed to cool down before removing the rear cover. Potential hazards include hot surfaces.

When placing the covers on the DAS, make certain that:

- The front cover is secured by its two front latches (this is to prevent users/operators from accessing service areas).
- The rear cover is screwed into place with its original screws.

EQUIPMENT HANDLING PRECAUTIONS

Observe all conventional ESD precautions when handling LaCie 8big Rack Thunderbolt 2 internal components. Avoid contact with backplane components, module components, etc.

Hard drives are fragile and must be handled with care during removal/replacement.

DATA SECURITY

Any loss, corruption, or destruction of data while using a LaCie hard drive or a LaCie hard drive system is the sole responsibility of the user, and under no circumstances will LaCie be held liable for the recovery or restoration of this data. To help prevent the loss of your data, LaCie highly recommends that you keep TWO copies of your data: one copy on your DAS; and, a second copy on one of the following:

- Direct-attached storage (DAS)
- A second DAS
- Some form of removable storage or archival media

Important Info: 1GB = 1,000,000,000 bytes. 1TB = 1,000,000,000,000 bytes. Once formatted, the actual available storage capacity varies depending upon the operating environment (typically 10-15% less).

WARRANTY INFORMATION

Please read this page carefully in order to understand your warranty rights and responsibilities.

1. If your product's warranty is still valid and you wish to receive support, please contact LaCie technical support. In order to do this, you must first create an account [here](#).
2. LaCie discourages customers from performing repairs to the product that are not explained in this manual.
3. Please contact LaCie technical support before performing hardware repairs.
4. Please save your packaging. If LaCie technical asks you to send the product for servicing, it must be returned in its original packaging.
5. If LaCie technical asks you to send the product for servicing, first remove the hard drives and any post-factory components (RAM, riser card, PCIe card, etc.) you have installed. Note that if you send hard drives with the chassis, they will be reformatted and all data erased unless data recovery is a part of the service rendered.

Note: It's possible to purchase a warranty upgrade for this product. Upgrades entitle you to a warranty extension up to five years and other benefits such as Advanced Care Option or data recovery. Refer to www.lacie.com/warranties for details.

LaCie offers first-rate service and support through our generous three-tiered warranty policy. Our 1-, 2-, 3-, and 5-year policies include comprehensive, complimentary web-based resources, expert in-house technical support, and worldwide repair and/or replacement coverage. To benefit from this warranty, please contact LaCie Support at www.lacie.com/us/support where you can find online support and contact information. You may also contact representatives at the original point of purchase who will be able to help guide you.

Standard warranties vary depending on the product. To verify your product's warranty status and to see which standard warranty is included with your product, type in your product's serial number at www.lacie.com/us/support. If no warranty is listed under your product's name, this means that the warranty has expired.

WARRANTY UPGRADES

If you wish to extend your warranty coverage, you can purchase Silver, Gold, or Platinum Care or Advanced Exchange. For details, see www.lacie.com/warranties.

LEGAL INFORMATION

A standard LaCie limited warranty is included with all products. Please read the terms and conditions below.

LaCie Limited Warranty Policy

LaCie ("LaCie") warrants, to the original purchaser, that this equipment shall be free of defects in materials and workmanship for a period of one (1), two (2), three (3), or five (5) years, depending on the model, from LaCie's date of original shipment when the equipment is used normally and is properly serviced when needed. If you

discover a defect covered by the warranty set forth above, your sole and exclusive remedy will be for LaCie, in its sole discretion to (i) repair or replace the product at no charge to you; or, if a repaired unit or replacement product is not available, (ii) to refund the current market value of your product. You acknowledge and agree that replacement product, at the sole option of LaCie, may be a new product or a remanufactured product. In order to receive the remedy set forth above, you must return the product during the warranty period and include with each returned product (i) a copy of your original purchase invoice to verify your warranty; (ii) a Return Material Authorization number; (iii) your name, address and telephone number; (iv) a copy of the bill of sale bearing the appropriate LaCie serial numbers as proof of date of original retail purchase; and (v) a description of the problem. The customer must pay all transportation costs for a returned product. The product will need to be returned to LaCie within the country of original retail purchase. This warranty applies only to hardware products; LaCie software, media, and manuals are licensed and warranted pursuant to separate written agreement. This warranty does not apply if the product has been misused or has been damaged by accident, abuse, misuse, or misapplication; if it has been modified without permission of LaCie; or if any LaCie serial number has been removed or defaced. If a customer has purchased a LaCie Advance Care Option (ACO) to go with this equipment, the ACO shall be valid for three (3) years from activation.

EXCEPT FOR THE LIMITED WARRANTY SET FORTH ABOVE, ALL PRODUCTS ARE SOLD "AS IS" AND LACIE EXPRESSLY DISCLAIMS ALL WARRANTIES OF ANY KIND, WHETHER EXPRESS, IMPLIED OR STATUTORY, INCLUDING THE IMPLIED WARRANTIES OF MERCHANTABILITY, NONINFRINGEMENT AND FITNESS FOR A PARTICULAR PURPOSE. WITHOUT FURTHER LIMITING THE GENERALITY OF THE FOREGOING, DOES NOT WARRANT (1) THE PERFORMANCE OR RESULTS OBTAINED FROM USING THIS PRODUCT, (2) THAT THE PRODUCT IS APPROPRIATE FOR THE CUSTOMER'S PURPOSES, (3) THE MANUAL IS ERROR FREE, OR (4) THAT NO DATA WILL BE LOST WHILE USING THE PRODUCT. THE ENTIRE RISK AS TO THE RESULTS AND PERFORMANCE IS ASSUMED BY THE CUSTOMER. THE WARRANTY AND REMEDIES SET FORTH ABOVE ARE EXCLUSIVE AND IN LIEU OF ALL OTHERS, ORAL OR WRITTEN, EXPRESS OR IMPLIED.

EXCLUSIONS AND LIMITATIONS

This Limited Warranty applies only to hardware products manufactured by or for LaCie that can be identified by the "LaCie" trademark, trade name, or logo affixed to them. The Limited Warranty does not apply to any non-LaCie hardware products or any software, even if packaged or sold with LaCie hardware. Manufacturers, suppliers, or publishers, other than LaCie, may provide their own warranties to the end user purchaser, but LaCie, in so far as permitted by law, provides their products "as is". Software distributed by LaCie with or without the LaCie brand name (including, but not limited to system software) is not covered under this Limited Warranty. Refer to the licensing agreement accompanying the software for details of your rights with respect to its use.

LaCie does not warrant that the operation of the product will be uninterrupted or error-free. LaCie is not responsible for damage arising from failure to follow instructions relating to the product's use. This warranty does not apply: (a) to consumable parts, unless damage has occurred due to a defect in materials or workmanship; (b) to cosmetic damage, including but not limited to scratches, dents and broken plastic on ports; © to damage caused by use with non-LaCie products; (d) to damage caused by accident, abuse, misuse, flood, fire, earthquake or other external causes; (e) to damage caused by operating the product outside the permitted or intended uses described by LaCie; (f) to damage caused by service (including upgrades and expansions) performed by anyone who is not a representative of LaCie or a LaCie Authorized Service Provider; (g) to a product or part that has been modified to alter functionality or capability without the written permission of LaCie; or (h) if any LaCie serial number on the product has been removed or defaced.

No LaCie dealer, agent, or employee is authorized to make any modification, extension, or addition to this warranty.

Any loss, corruption or destruction of data while using a LaCie drive is the sole responsibility of the user, and under no circumstances will LaCie be held liable for the recovery or restoration of this data. To help prevent the loss of your data, LaCie highly recommends that you keep TWO copies of your data; one copy on your external hard disk, for instance, and a second copy either on your internal hard disk, another external hard disk or some other form of removable storage media. LaCie offers a complete line of CD and DVD drives. If you would like more information on backup, please refer to our website.

LACIE IS NOT RESPONSIBLE FOR SPECIAL, INCIDENTAL, OR CONSEQUENTIAL DAMAGES RESULTING FROM ANY BREACH OF WARRANTY, OR UNDER ANY LEGAL THEORY, INCLUDING LOST PROFITS, DOWNTIME, GOODWILL, DAMAGE TO OR REPLACEMENT OF EQUIPMENT AND PROPERTY, AND ANY COSTS OF RECOVERING, REPROGRAMMING, OR REPRODUCING ANY PROGRAM OR DATA STORED IN OR USED WITH LACIE PRODUCTS EVEN IF IT HAS BEEN ADVISED OF THE POSSIBILITY OF SUCH DAMAGES.

Some states do not allow the exclusion or limitation of implied warranties or liability for incidental or consequential damages, so the above limitation or exclusion may not apply to you. This warranty gives you specific legal rights, and you may have other rights, which vary from state to state.

Your opening of your package, your use of the product, or your return of the enclosed Registration Card acknowledges that you have read and agree to the terms of this Agreement. You further agree that it is the complete and exclusive state of the agreement between us and supersedes any proposal or prior agreement, oral or written, and any other communications between us relating to the subject matter of this Agreement.

Read carefully all information related to warranty and precautions of use of your new LaCie product in the user manual.

For products purchased in the United States, you may contact LaCie at 7555 Tech Center Drive, Tigard, Oregon 97223 USA. Email: sales@lacie.com. Website: www.lacie.com. Customer service: 503-844-4503.

Service DOA

On rare occasions, a newly purchased LaCie product may be delivered in non-working order. We are working to avoid these issues, but unfortunately, these situations may arise from time to time. Within the 15 calendar days of purchase, should you experience an issue with your new LaCie product, we ask you to return the product to the place where it was originally bought. You will be required to give a proof of purchase.

Customer Warning

Please be sure to back up your data before returning your drive to LaCie for repair. LaCie cannot under any circumstances guarantee the integrity of data remaining on a returned drive. We make no provisions for data recovery and cannot be held liable for any data loss on drives or media returned to LaCie.

All products returned to LaCie must be securely packaged in their original box and shipped with postage prepaid, except for Products registered under the Advance Care Option.

NOTE TO AUSTRALIAN CUSTOMERS

Our goods come with guarantees that cannot be excluded under the Australian Consumer Law. You are entitled to a replacement or refund for a major failure and for compensation for any other reasonably foreseeable loss or damage. You are also entitled to have the goods repaired or replaced if the goods fail to be of acceptable quality and the failure does not amount to a major failure.

Contact us:

LaCie Australia, 6/151 Beauchamp Rd, Matraville NSW 2036 AUSTRALIA

Phone: 02 8063 3711

Email: info.au@lacie.com

For fast technical support, create a support ticket after registering your product at www.lacie.com/au/register.

LEGAL INFO

COPYRIGHTS

Copyright © 2015 LaCie. All rights reserved. No part of this publication may be reproduced, stored in a retrieval system, or transmitted in any form or by any means, electronic, mechanical, photocopying, recording or otherwise, without the prior written consent of LaCie.

CHANGES

The material in this document is for information only and subject to change without notice. While reasonable efforts have been made in the preparation of this document to assure its accuracy, LaCie assumes no liability resulting from errors or omissions in this document, or from the use of the information contained herein. LaCie reserves the right to make changes or revisions in the product design or the product manual without reservation and without obligation to notify any person of such revisions and changes.

FEDERAL COMMUNICATION COMMISSION INTERFERENCE STATEMENT

This equipment has been tested and found to comply with the limits for a Class A digital device, pursuant to Part 15 of the FCC Rules. These limits are designed to provide reasonable protection against harmful interference in a residential installation. This equipment generates, uses and can radiate radio frequency energy and, if not installed and used in accordance with the instructions, may cause harmful interference to radio communications. However, there is no guarantee that interference will not occur in a particular installation. If this equipment does cause harmful interference to radio or television reception, which can be determined by turning the equipment off and on, the user is encouraged to try to correct the interference by one of the following measures:

1. Reorient or relocate the receiving antenna.
2. Increase the separation between the equipment and receiver.
3. Connect the equipment into an outlet on a circuit different from that to which the receiver is connected.
4. Consult the dealer or an experienced radio/TV technician for help.

FCC Caution: Any changes or modifications not expressly approved by the party responsible for compliance could void the user's authority to operate this equipment.

This device complies with Part 15 of the FCC Rules. Operation is subject to the following two conditions: (1) This device may not cause harmful interference, and (2) this device must accept any interference received, including interference that may cause undesired operation.

Important info: FCC Radiation Exposure Statement: This equipment complies with FCC radiation exposure limits set forth for an uncontrolled environment. This equipment should be installed and operated with minimum distance 20 cm between the radiator & your body.

This transmitter must not be co-located or operating in conjunction with any other antenna or transmitter. The availability of some specific channels and/or operational frequency bands are country dependent and are

firmware programmed at the factory to match the intended destination. The firmware setting is not accessible by the end user.

WEEE



This symbol on the product or on its packaging indicates that this product must not be disposed of with your other household waste. Instead, it is your responsibility to dispose of your waste equipment by handing it over to a designed collection point for the recycling of waste electrical and electronic equipment. The separate collection and recycling of your waste equipment at the time of disposal will help to conserve natural resources and ensure that it is recycled in a manner that protects human health and the environment. For more information about where you can drop off your waste equipment for recycling, please contact your local city office, your household waste disposal service, or the shop where you purchased the product.

TRADEMARKS

Apple, Mac, Time Machine, and Macintosh are registered trademarks of Apple Computer, Inc. Microsoft, Windows XP, Windows Vista, and Windows 7 are registered trademarks of Microsoft Corporation. Other trademarks mentioned in this manual are the property of their respective owners.

CANADA COMPLIANCE STATEMENT

This Class A digital apparatus meets all requirements of the Canadian Interference-Causing Equipment Regulations.

CAN ICES-3 (A)/NMB-3(A)

MANUFACTURER'S DECLARATION FOR CE CERTIFICATION



We, LaCie, solemnly declare that this product conforms to the following European standards: Electromagnetic Compatibility Directive (2004/108/EC); Low-Voltage Directive: 2006/95/EC

¹ 1.Thunderbolt and the Thunderbolt logo are trademarks of Intel Corporation in the U.S. and/or other countries.